

DISASSEMBLY AND ASSEMBLY

CHAPTER

TABLE OF CONTENTS

<i>Section</i>	<i>Title</i>	<i>Page</i>
4.1	GENERAL REPAIR INFORMATION	4-1
4.2	MAIN UNIT DISASSEMBLY AND ASSEMBLY	4-2
4.2.1	Option Cover and Upper Case Removal	4-2
4.2.2	Option Cover and Upper Case Replacement	4-2
4.2.3	Q10 PS Power Supply Board Removal	4-3
4.2.4	Q10 PS Power Supply Board Replacement	4-3
4.2.5	APX-IGGS Video Board Removal	4-4
4.2.6	APX-IGGS Video Board Replacement	4-4
4.2.7	APX-ICRT Video Board Removal	4-5
4.2.8	APX-ICRT Video Board Replacement	4-5
4.2.9	APX-ISYM Board Removal	4-6
4.2.10	APX-ISYM Board Replacement	4-6
4.2.11	Fan Removal	4-8
4.2.12	Fan Replacement	4-8
4.3	FLOPPY DISK DRIVE DISASSEMBLY AND ASSEMBLY	4-9
4.3.1	FDD Unit Removal	4-9
4.3.2	FDD Unit Replacement	4-9
4.3.3	FDD Control Board Removal	4-10
4.3.4	FDD Control Board Replacement	4-10
4.3.5	Front Panel Removal	4-11
4.3.6	Front Panel Replacement	4-11
4.3.7	Collet, Subframe, and Index Sensor Removal	4-12
4.3.8	Collet, Subframe, and Index Sensor Replacement	4-12
4.3.9	Track 00 Sensor and Jacket Lifter Removal	4-13
4.3.10	Track 00 Sensor and Jacket Lifter Replacement	4-13
4.3.11	Stepper Motor Removal	4-14
4.3.12	Stepper Motor Replacement	4-14
4.3.13	Head Carriage Removal	4-15
4.3.14	Head Carriage Replacement	4-15
4.3.15	Motor Control Board Removal	4-16
4.3.16	Motor Control Board Replacement	4-16
4.4	KEYBOARD DISASSEMBLY AND ASSEMBLY	4-17
4.4.1	Keyboard Case Removal	4-17
4.4.2	Keyboard Case Replacement	4-17
4.4.3	Keyboard Circuit Board Removal	4-18
4.4.4	Keyboard Circuit Board Replacement	4-18

<i>Section</i>	<i>Title</i>	<i>Page</i>
4.5	MONITOR DISASSEMBLY AND ASSEMBLY	4-19
4.5.1	Monitor Upper Case Removal	4-19
4.5.2	Monitor Upper Case Replacement	4-19
4.5.3	Lower Case Removal	4-20
4.5.4	Lower Case Replacement	4-20
4.5.5	Power Transformer Removal	4-21
4.5.6	Power Transformer Replacement	4-21
4.5.7	Monitor Circuit Board Removal	4-22
4.5.8	Monitor Circuit Board Replacement	4-22
4.5.9	Brightness Control Removal	4-23
4.5.10	Brightness Control Replacement	4-23
4.5.11	Power Switch Removal	4-24
4.5.12	Power Switch Replacement	4-24
4.5.13	CRT Removal	4-25
4.5.14	CRT Replacement	4-25

LIST OF FIGURES

<i>Figure</i>	<i>Title</i>	<i>Page</i>
4-1	Upper Case Removal/Replacement	4-2
4-2	Q10 PS Power Supply Removal/Replacement	4-3
4-3	APX-IGGS Video Board Removal/Replacement	4-4
4-4	APX-ICRT Removal/Replacement	4-5
4-5	APX-ISYM Control Board Removal/Replacement	4-7
4-6	Fan Removal/Replacement	4-8
4-7	FDD Unit Removal/Replacement	4-9
4-8	FDD Control Board Removal/Replacement	4-10
4-9	Front Panel Removal/Replacement	4-11
4-10	Collet, Subframe, and Index Sensor Removal/Replacement	4-12
4-11	Track 00 Sensor Removal/Replacement	4-13
4-12	Stepper Motor Removal/Replacement	4-14
4-13	Head Carriage Removal/Replacement	4-15
4-14	Motor Control Board Removal/Replacement	4-16
4-15	Keyboard Case Removal/Replacement	4-17
4-16	Keyboard Circuit Board Removal/Replacement	4-18
4-17	Monitor Upper Case Removal/Replacement	4-19
4-18	Monitor Lower Case Removal/Replacement	4-20
4-19	Power Transformer Removal/Replacement	4-21
4-20	Monitor Circuit Board Removal/Replacement	4-22
4-21	Brightness Control Removal/Replacement	4-23
4-22	Power Switch Removal/Replacement	4-24
4-23	CRT Removal/Replacement	4-25

LIST OF TABLES

<i>Table</i>	<i>Title</i>	<i>Page</i>
4-1	Repair Tools and Equipment	4-1

4.1 GENERAL REPAIR INFORMATION

This section provides procedures for removal and replacement of the major subassemblies of the QX-16. Recommended repair tools are listed in Table 4-1 with corresponding EPSON part numbers; these tools are also commercially available.

TABLE 4-1. REPAIR TOOLS AND EQUIPMENT

TOOL	PART NUMBER
Flat-blade screwdriver (#1)	B743000100
Phillips screwdriver (#1)	B743800100
Phillips screwdriver (#2)	B743800200
E-ring holder (#2.5)	B740800400
E-ring holder (#1.5)	B740800200
Torque driver	B740100102
Tweezers	B741000100
Hex Nut Driver
Soldering iron	B740200100

DANGER

THE MONITOR IN THIS SYSTEM INCLUDES HIGH VOLTAGE CIRCUITRY. DISCONNECT THE MONITOR FROM THE AC OUTLET BEFORE DISASSEMBLY. IMMEDIATELY AFTER REMOVING THE MONITOR CASE, USE A SCREWDRIVER OR SIMILAR DEVICE TO SHORT THE ANODE OF THE CRT TO THE CONDUCTIVE CABLE ON THE TUBE. DO NOT ATTEMPT TO DISCHARGE THE ANODE BY CONNECTING IT WITH ISOLATED PARTS OF THE MONITOR, AS THIS MAY PRODUCE A SHOCK HAZARD.

WARNING

The circuit boards contain static-sensitive CMOS ICs and must be handled with care. Discharge bodily static before removing circuit boards, and wear a grounded wrist strap during disassembly. Place the boards on a rubber mat or similar non-static surface when removed from the case.

4.2 MAIN UNIT DISASSEMBLY AND ASSEMBLY

4.2.1 Option Cover and Upper Case Removal (Figure 4-1)

1. Remove two screws (A) from the option cover and lift the cover from the main unit. Remove the option port shield (B) if present.
2. Use a flat-blade screwdriver to lift two caps (C) from the upper case, then remove four screws (D).
3. Remove cables (E) from disk drives A and B, and remove speaker connector CN14 (F), then lift the case to remove.
4. Remove ground wire (G).

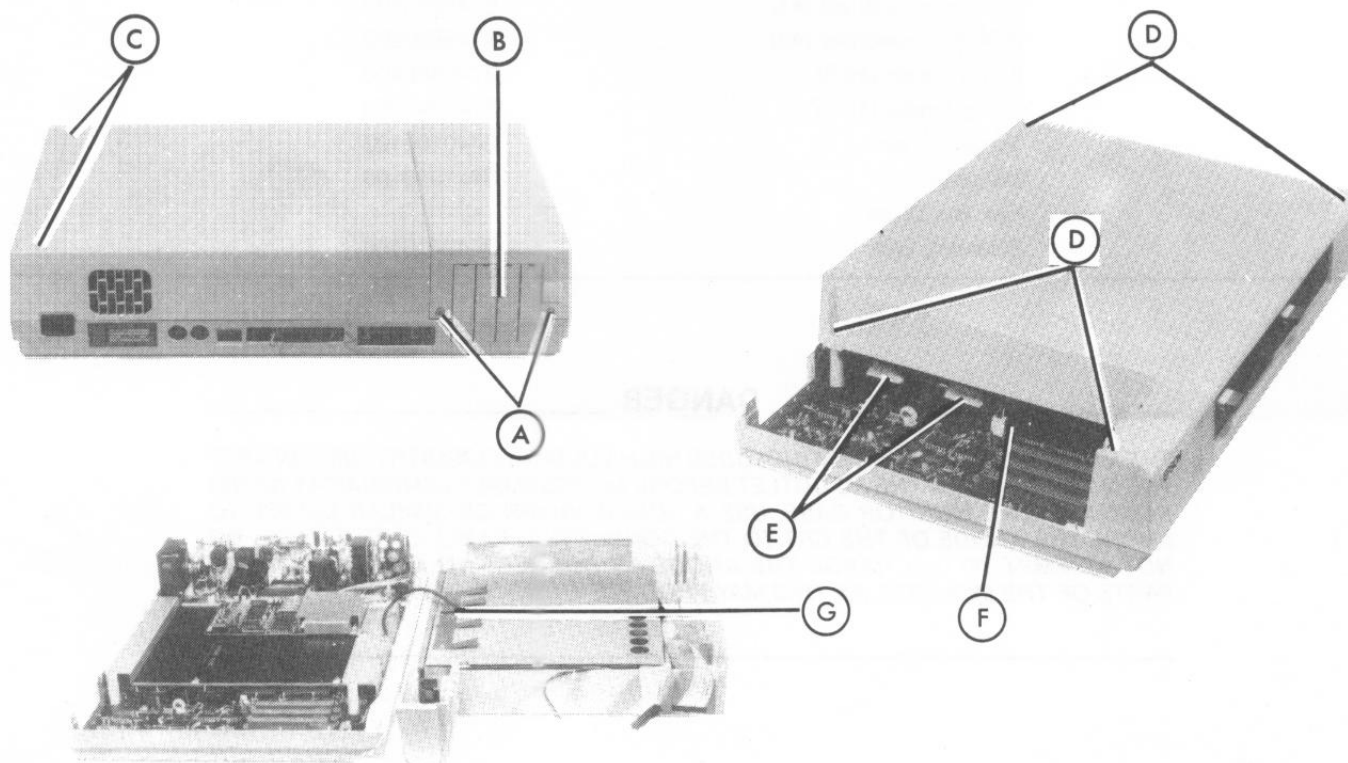

FIGURE 4-1. UPPER CASE REMOVAL/REPLACEMENT

4.2.2 Option Cover and Upper Case Replacement (Figure 4-1)

1. Install connectors (E) to drives A and B and connector CN14 (F) to the speaker, connect ground wire (G), then position the upper case on the lower case assembly.

NOTE: Make sure the FDD cables are not pinched between the grounding tabs on the video board and the case top.

2. Install the four Phillips screws (D) and two caps (C).
3. Install the option port shield (B) and the option cover; secure the cover with two screws (A).

4.2.3 Q10PS Power Supply Board Removal (Figure 4-2)

1. Remove the upper case (Section 4.2.1).
2. Disconnect CN8 (A) from the APX-ISYM board and remove four screws (B) which secure the power supply board to the lower case.
3. Lift the AC receptacle (C) and the rocker switch (D), and remove the power supply board from the lower case. (Do not disconnect the heat sink from the board.)

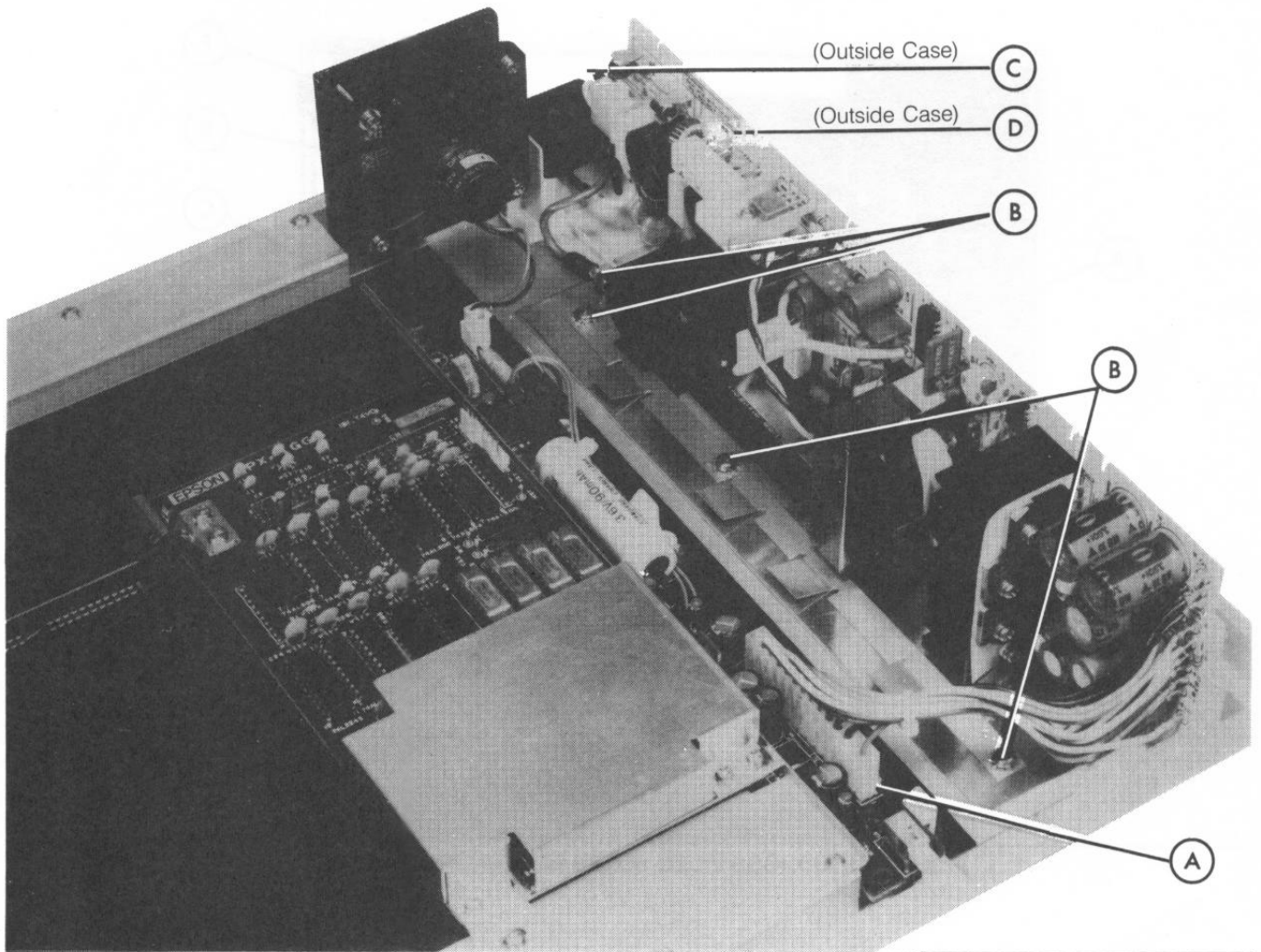

FIGURE 4-2. Q10PS POWER SUPPLY BOARD REMOVAL/REPLACEMENT

4.2.4 Q10PS Power Supply Board Replacement (Figure 4-2)

1. Install the power supply board in the lower case, positioning the rocker switch (D) and the AC receptacle (C).
2. Secure the board with four screws (B) and connect CN8 (A) to the APX-ISYM board.
3. Install the upper case (Section 4.2.2).

4.2.5 APX-IGGS Video Board Removal (Figure 4-3)

1. Remove the upper case (Section 4.2.1) and remove the APX- ICRT connector, CN1, from the APX-IGGS board.
2. Remove Phillips screw (A) and two Phillips cup screws (B), and lift the APX-IGGS board and shield straight up to remove.
3. Remove three Phillips screws (C) from shield plate (D); two of these also secure mounting plate (E).
4. Remove ground screw (F) and the accompanying nut and outside toothed lock washer.

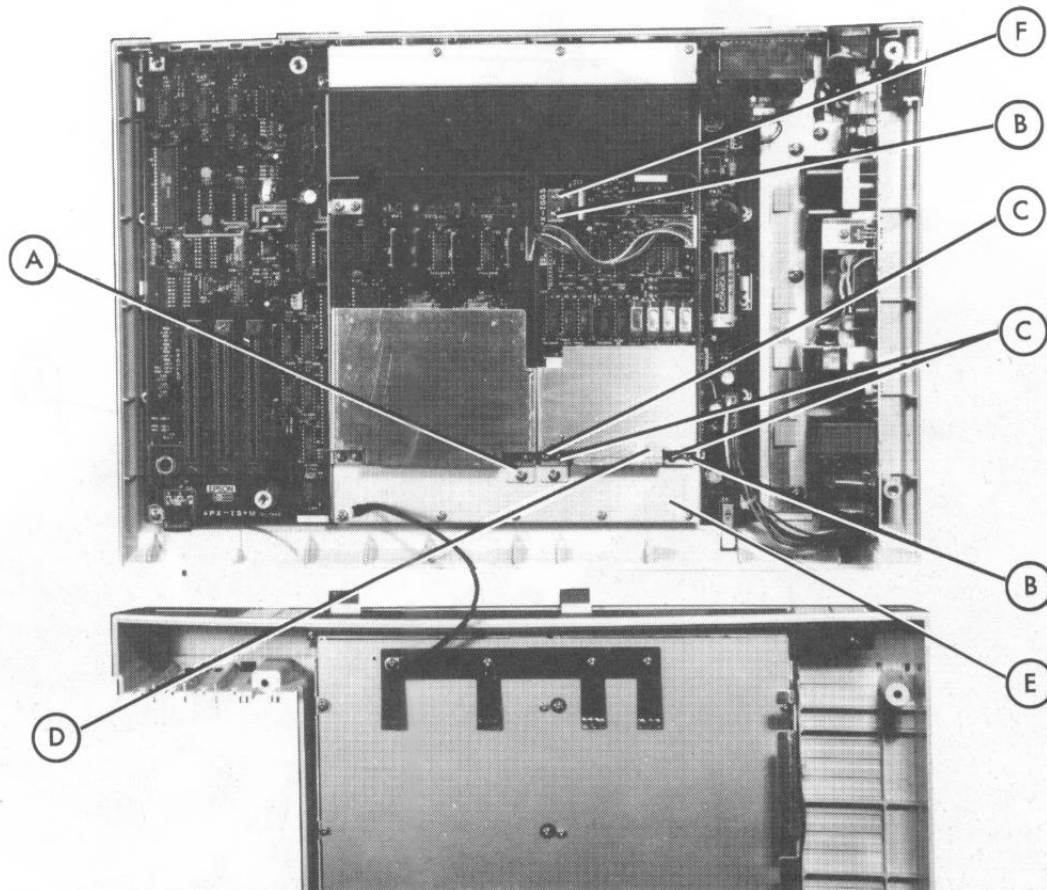

FIGURE 4-3. APX-IGGS VIDEO BOARD REMOVAL/REPLACEMENT

4.2.6 APX-IGGS Video Board Replacement (Figure 4-3)

1. Install Phillips screw (F) and the accompanying outside toothed lock washer and hex nut.
2. Install three Phillips screws (C) to secure shield plate (D) and mounting plate (E). Install an outside toothed lock washer and hex nut with the screw at the inside hole at the right-front corner.
3. Install the board assembly at keyed connectors CN9 and CN10, and install Phillips screw (A) and two Phillips cup screws (B).
4. Install the APX-ICRT connector, CN1, to the APX-IGGS board, then install the upper case (Section 4.2.2).

4.2.7 APX-ICRT Board Removal (Figure 4-4)

1. Remove the upper case (Section 4.2.1).
2. Remove CN1 (A) from the APX-IGGS board.
3. Remove three screws (B) to release the APX-ICRT assembly.
4. Remove three screws (C) to remove the shield from the board.

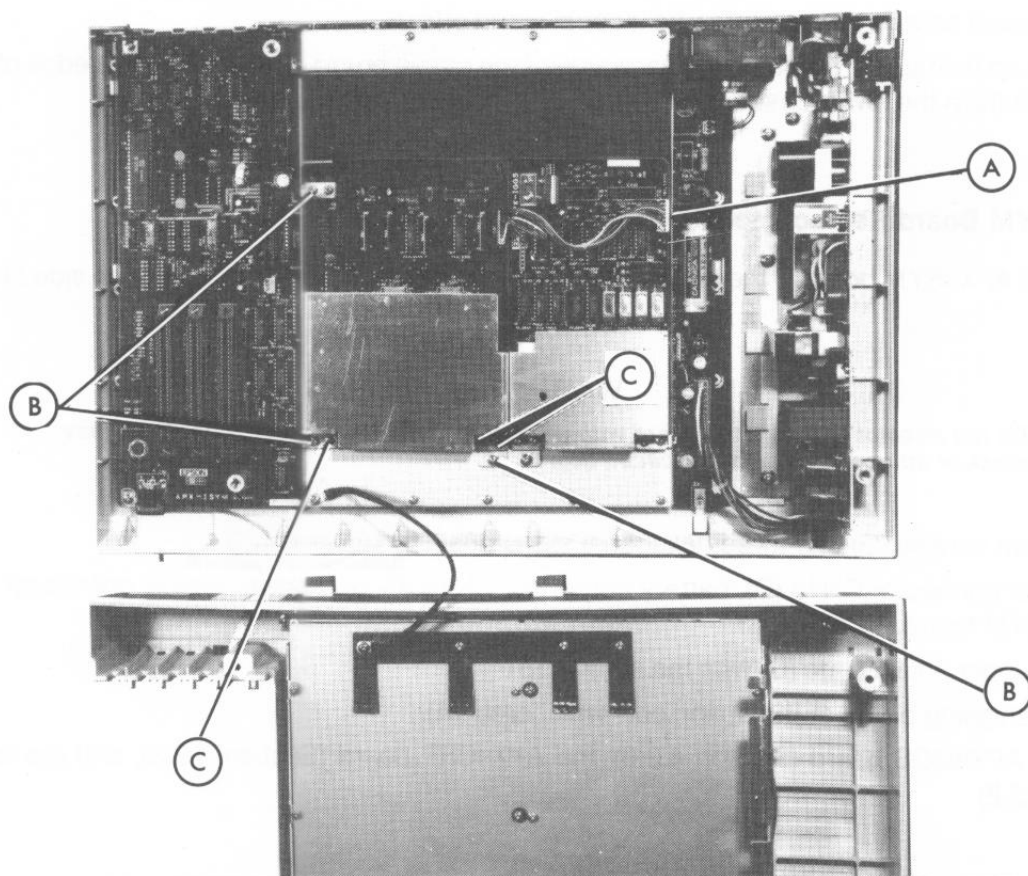

FIGURE 4-4. APX-ICRT BOARD REMOVAL/REPLACEMENT

4.2.8 APX-ICRT Board Replacement (Figure 4-4)

1. Install three screws (C) to secure the shield plate to the APX-ICRT board.
2. Install the APX-ICRT assembly with three screws (B).
3. Connect CN1 (A) to the APX-IGGS board.
4. Install the upper case (Section 4.2.2).

4.2.9 APX-ISYM Board Removal (Figure 4-5)

1. Remove the upper case (Section 4.2.1), the APX-IGGS board (Section 4.2.5), and the APX-ICRT board (Section 4.2.7).
2. Remove screw (A) from the shipping brace at the option slot.
3. Remove ten screws (B) from upper shield plate (C).
4. Disconnect fan connector CN13 (D), battery connector CN12 (E), and power supply connector CN8 (F) from the APX-ISYM board.
5. Remove eleven screws (G) and three hexagonal stand-offs (H).
6. Press back on the tabs (J) before lifting each side of the circuit board, then lift the front edge of the board to remove it from the lower case.

4.2.10 APX-ISYM Board Replacement (Figure 4-5)

1. Position the APX-ISYM board in the lower case and press back on tabs (J) to seat each side of the circuit board.

WARNING

Do not attempt to install the board without releasing the securing tabs; to do so may crack or otherwise damage the circuit board.

2. Install eleven screws (G) and three hexagonal stand-offs (H).
3. Connect fan connector CN13 (D), battery connector CN12 (E), and power supply connector CN8 (F) to the APX-ISYM board.
4. Install the upper shield plate (C) with ten screws (B).
5. Install the shipping brace at the option port with screw (A).
6. Install the APX-IGGS board (Section 4.2.6), the APX-ICRT board (Section 4.2.8), and the upper case (Section 4.2.2).

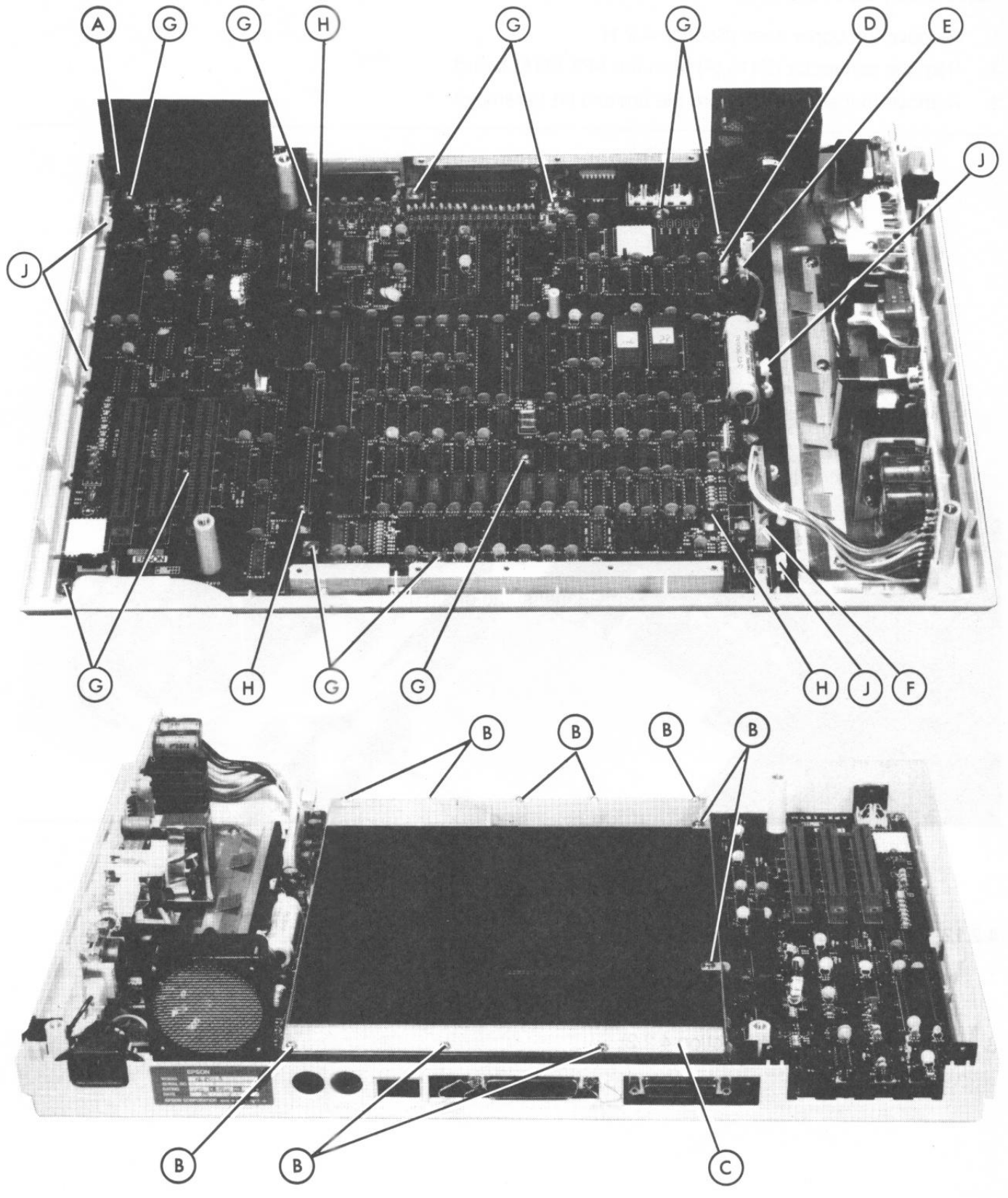

FIGURE 4-5. APX-ISYM CONTROL BOARD REMOVAL/REPLACEMENT.

4.2.11 Fan Removal (Figure 4-6)

1. Remove the upper case (Section 4.2.1).
2. Remove connector CN13 (A) from the APX-ISYM board.
3. Remove four screws (B) from the fan and lift to remove.

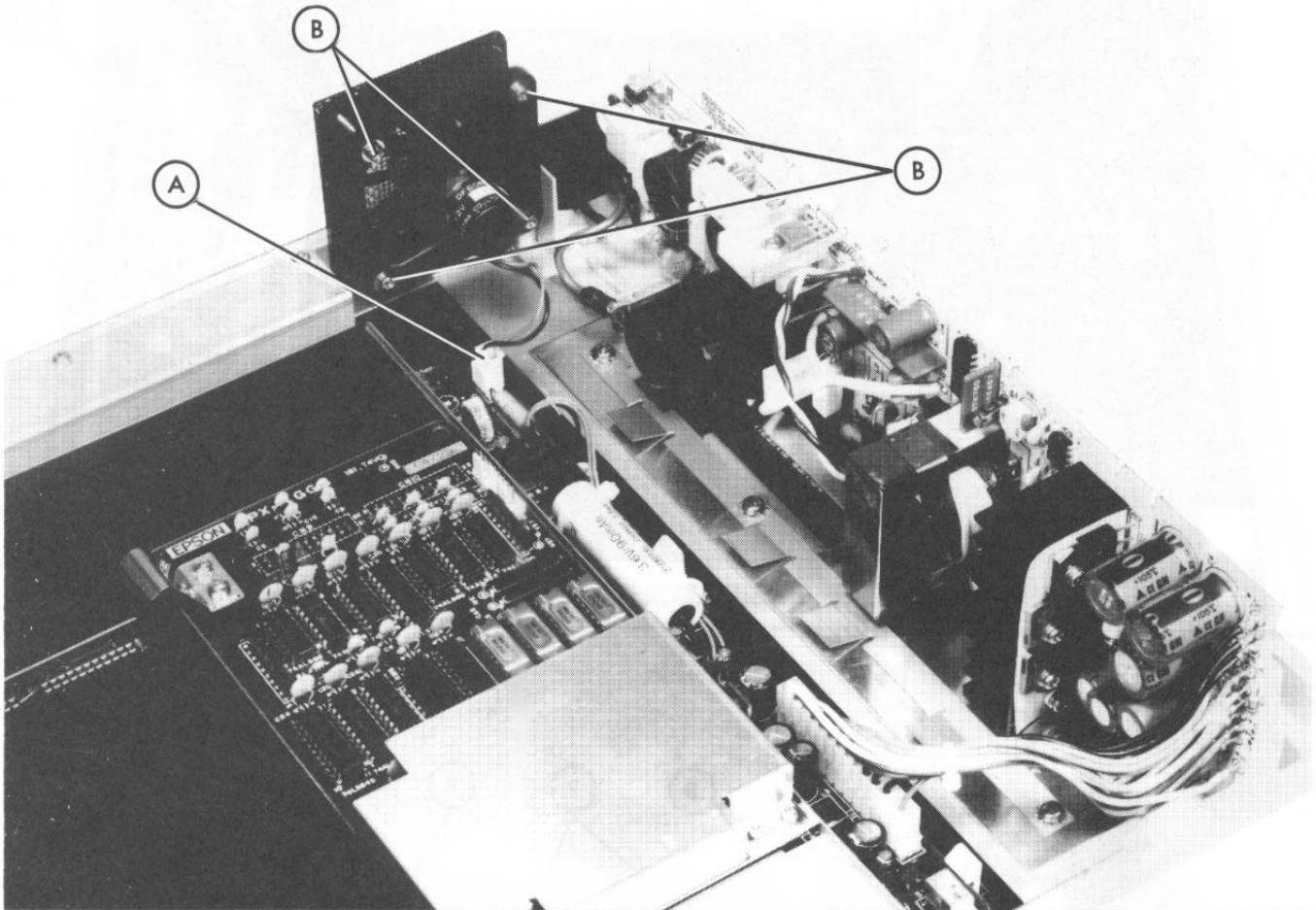

FIGURE 4-6. FAN REMOVAL/REPLACEMENT

4.2.12 Fan Replacement (Figure 4-6)

1. Install the fan with four screws (B).
2. Install fan connector CN13 (A) on the APX-ISYM board.
3. Install the upper case (Section 4.2.2).

4.3 FLOPPY DISK DRIVE DISASSEMBLY AND ASSEMBLY

4.3.1 FDD Unit Removal (Figure 4-7)

1. Remove the upper case (Section 4.2.1).
2. Remove four screws (A) from ground plate (B) and remove screw (C) from the LED power indicator, then remove the grounding plate.
3. Remove two screws (D) to remove drive A; remove two screws (E) to remove drive B. Slide the drive through the opening in the front case of the main unit to remove.

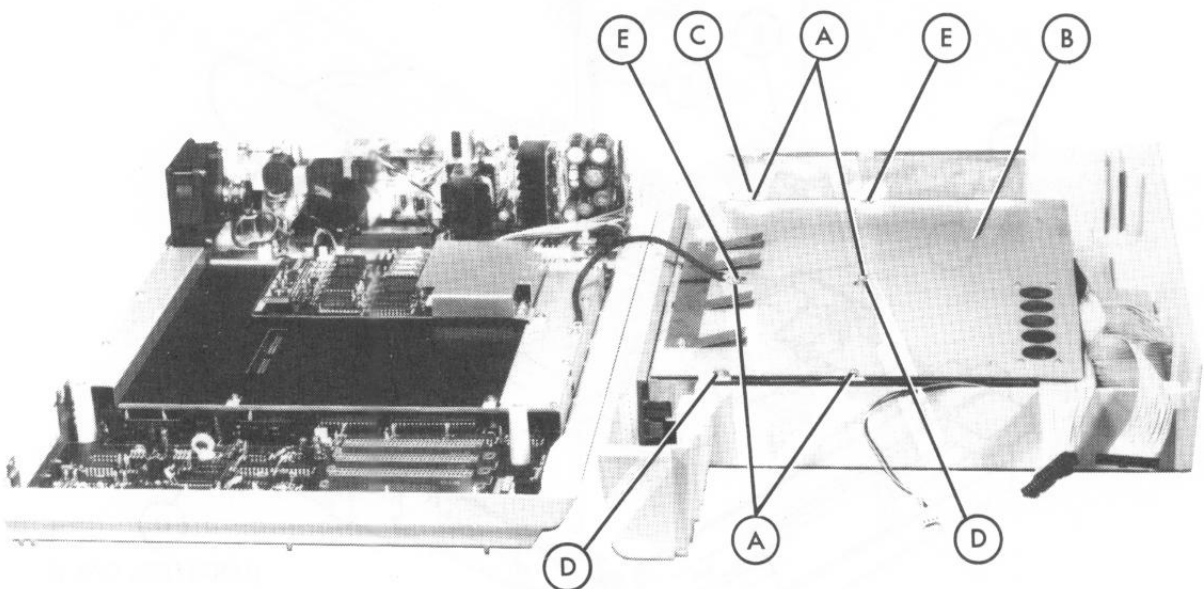

FIGURE 4-7. FDD UNIT REMOVAL/REPLACEMENT

4.3.2 FDD Unit Replacement (Figure 4-7)

1. Slide the drive through the opening in the front case. Install two screws (D) to secure drive A, and two screws (E) to secure drive B.
2. Install screw (C) to the LED power indicator, position grounding plate (B), then install four screws (A).
3. Install the upper case (Section 4.2.2)

4.3.3 FDD Control Board Removal (Figure 4-8)

1. Remove the FDD from the main unit (Section 4.3.1).
2. Remove two Phillips screws (A), lift shield plate (B), and remove LED (C) from the front panel.
3. Release head lead wires (D) from the wire restraint, remove the index connector leads from connector J4 (E), and remove screw (F) from the circuit board.
4. Remove the head connector wire at J5 (G) and lift the circuit board from the right edge, near J3.

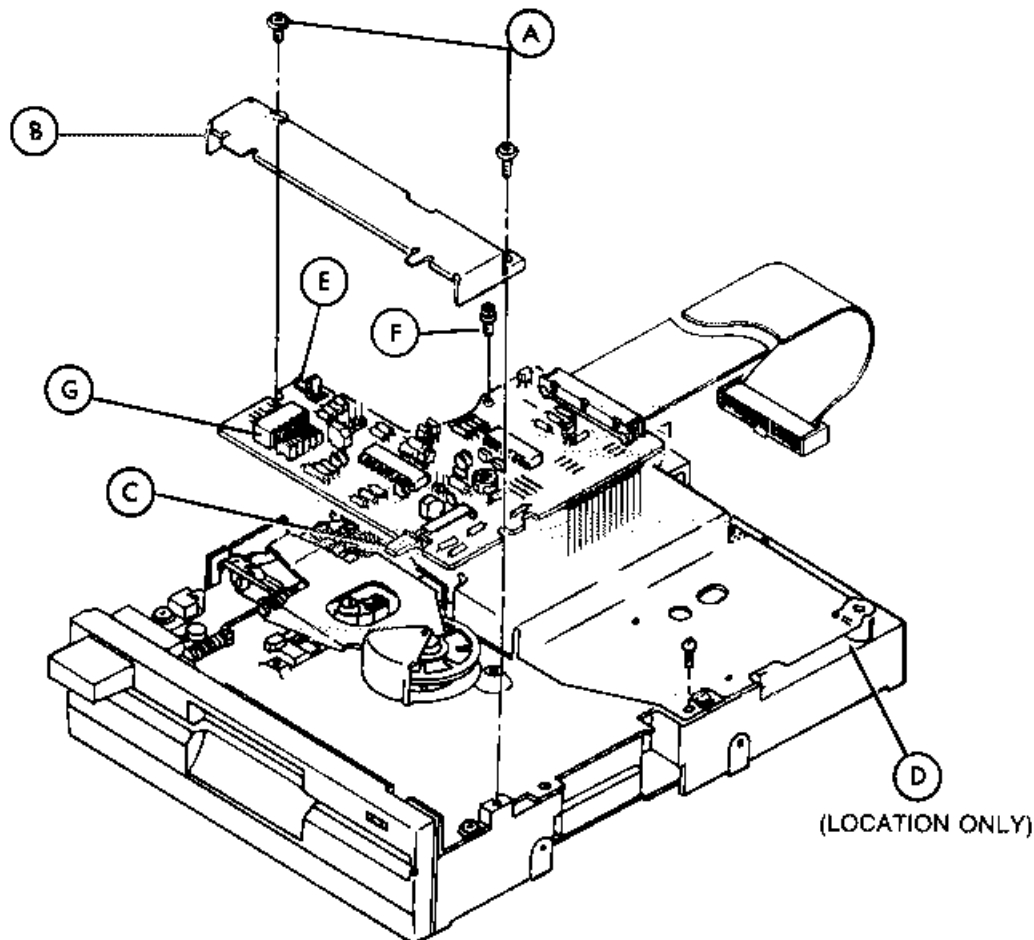

FIGURE 4-8. FDD CONTROL BOARD REMOVAL/REPLACEMENT

4.3.4 FDD Control Board Replacement (Figure 4-8)

1. Position the circuit board on the mechanism frame and install the head connector wire at J5 (G). The head lead wires must be positioned at the right side of the mechanism frame, and covered with a plastic shield.
2. Install screw (F) in the main circuit board.
3. Install index detector connector (E), and position the head lead wires (D) under the wire restraints.
4. Install LED (C) in the front panel, and replace shield plate (B) with two Phillips screws (A).
5. Install the drive in the main unit (Section 4.3.2).

4.3.5 Front Panel Removal (Figure 4-9)

1. Remove the FDD control board (Section 4.3.3).
2. Remove two Phillips screws (A) to remove panel (B).

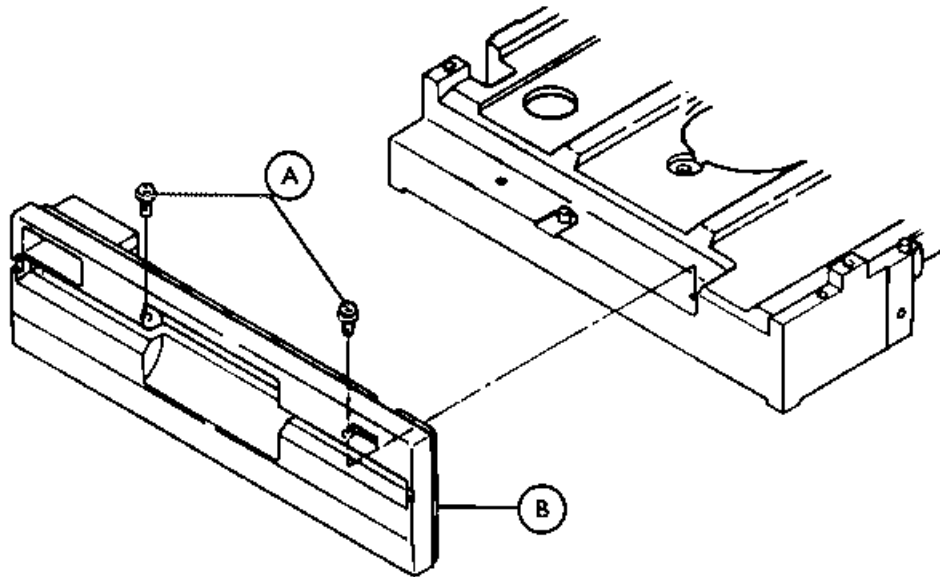

FIGURE 4-9. FRONT PANEL REMOVAL/REPLACEMENT

4.3.6 Front Panel Replacement (Figure 4-9)

1. Secure the front panel (B) to the mechanism frame with two screws (A).
2. Install the FDD control board (Section 4.3.4).

4.3.7 Collet, Subframe, and Index Sensor Removal (Figure 4-10)

1. Remove the FDD unit from the case (Section 4.3.1) and remove the FDD control board (Section 4.3.3).
2. Remove three screws (A) to remove shield plate (B).
3. Insert a protective strip of paper or light cardboard between the upper and lower heads, then remove four screws (C) and subframe assembly (D).
4. Push collet lever (E) down until collet (F) is free from the the collet guide shaft. Slide the collet away from the collet lever until free.
5. Remove E-ring (G) from collet lever shaft (H)
6. To remove the index sensor, remove screw (K) and lift the sensor from the mechanism.

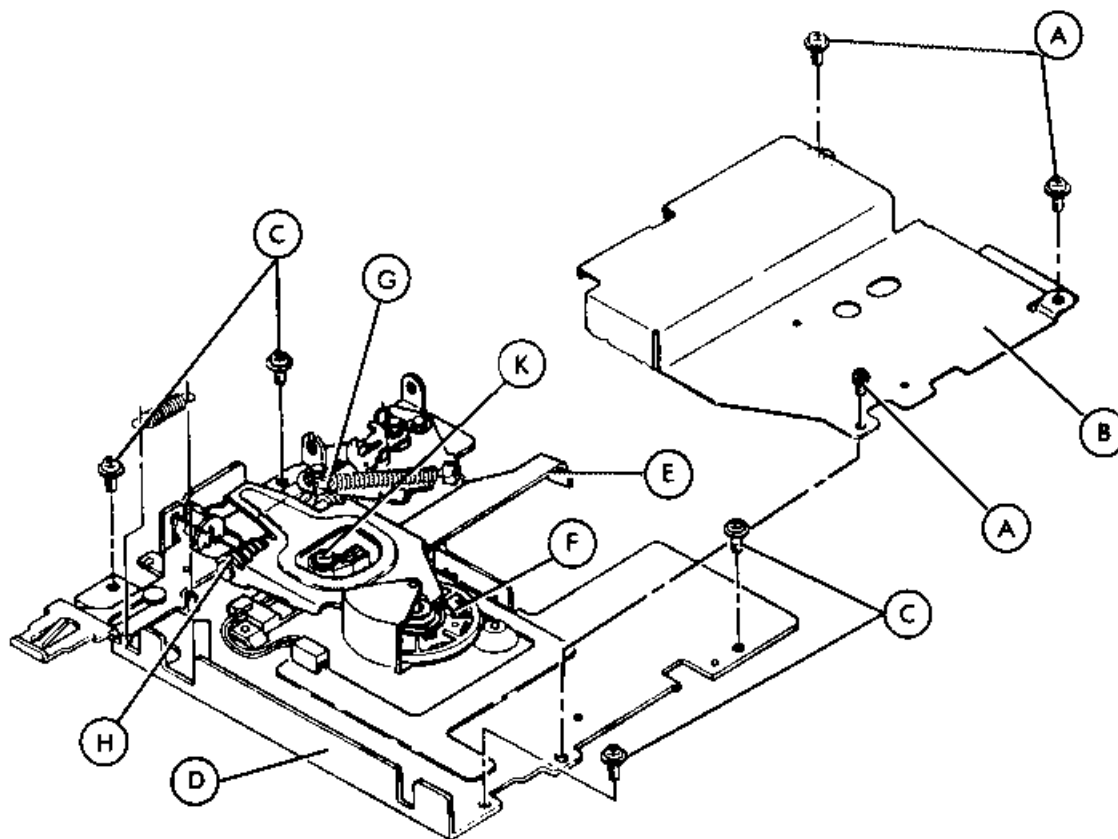

FIGURE 4-10. COLLET, SUBFRAME, AND INDEX SENSOR REMOVAL/REPLACEMENT

4.3.8 Collet, Subframe, and Index Sensor Replacement (Figure 4-10)

1. Install the index sensor and secure with screw (K).
2. Install collet lever (E), shaft (H), E-ring (G), and the spring.
3. Depress collet lever (E), slide collet (F) on to the end of the lever, and raise the lever, making certain the collet is centered on the guide shaft.
4. Install subframe (D) and screws (C).
5. Install shield plate (B) and three screws (A), and install the FDD unit in the case (Section 4.3.2).

4.3.9 Track 00 Sensor and Jacket Lifter Removal (Figure 4-11)

1. Remove the FDD from the case (Section 4.3.1) and remove the FDD control circuit board (Section 4.3.3).
2. Remove the front panel (Section 4.3.5) and the FDD control board shield plate.
3. Remove the track 00 sensor connector (A) from the motor control board.
4. Remove screw (B), slide the sensor free of the mechanism, and lift straight up to remove the sensor from the frame.
5. Remove the jacket lifter (C) and jacket lifter spring (D), as necessary.

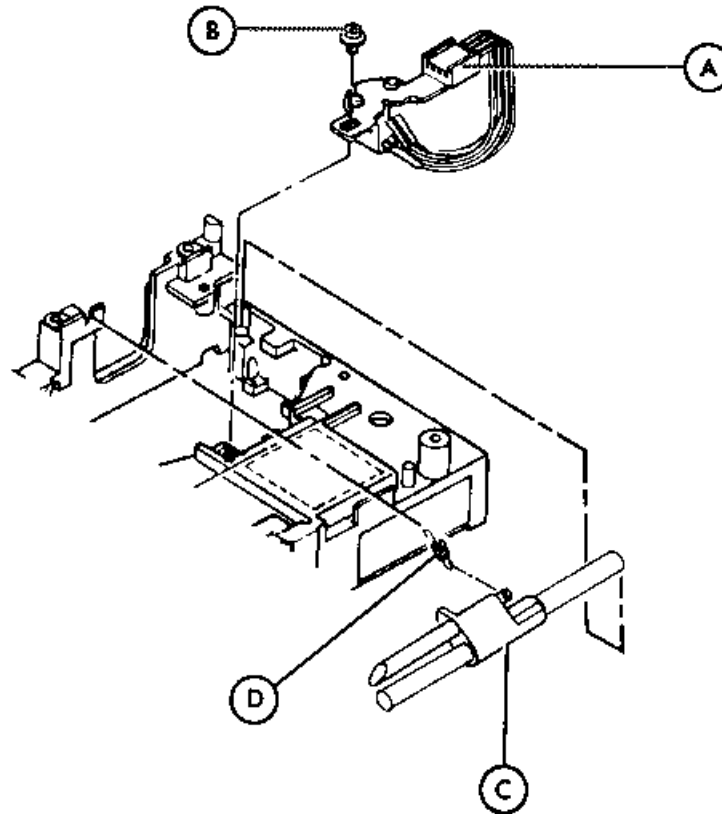

FIGURE 4-11. TRACK 00 SENSOR REMOVAL/REPLACEMENT

4.3.10 Track 00 Sensor and Jacket Lifter Replacement (Figure 4-11)

1. Install jacket lifter (C) and lifter spring (D), if removed.
2. Install the track 00 sensor in the frame with screw (B), and install the sensor connector (A) on the main board.
3. Install the FDD control board shield plate.
4. Install the front panel (Section 4.3.6) and the FDD control board (Section 4.3.4).
5. Adjust the track 00 sensor. (Refer to Section 5.3.5.)

4.3.11 Stepper Motor Removal (Figure 4-12)

1. Remove the FDD unit from the case (Section 4.3.1), and remove the FDD control board (Section 4.3.3).
2. Remove the front panel (Section 4.3.5), and the subframe (Section 4.3.7).
3. Remove the track 00 sensor and jacket lifter spring (Section 4.3.9).
4. Disconnect the motor circuit lead wires (A) from the motor control board.
5. Lift jacket lifter (B) up and forward and rest it on the frame. Remove screws (C) from the ends of the steel belt. Use flat-tipped tweezers to lift the steel belt above the screw posts.
6. Remove screws (D) from the stepper motor bracket and remove the motor from the frame.
7. Turn the steel belt tensioner (E) to release it from the frame.

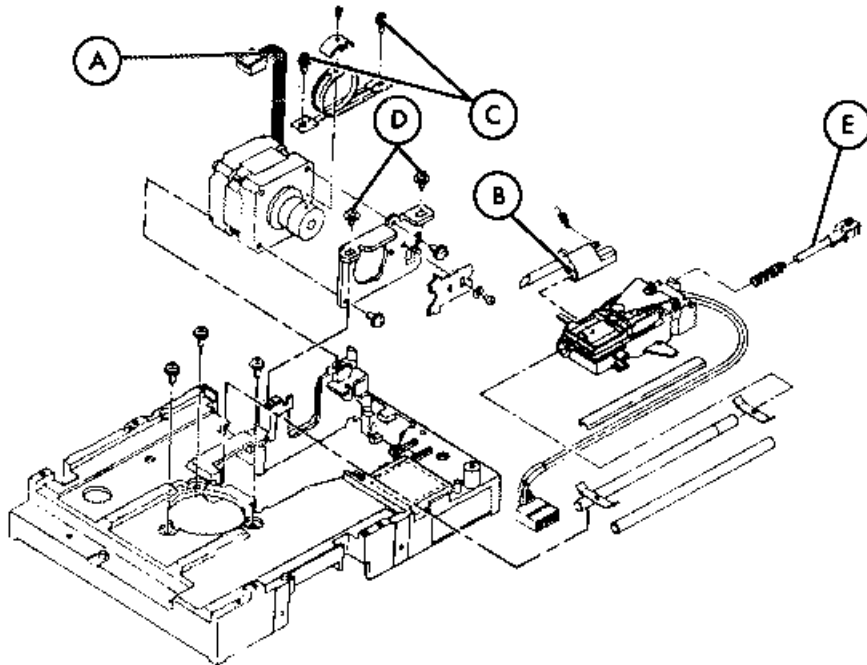

FIGURE 4-12. STEPPER MOTOR REMOVAL/REPLACEMENT

4.3.12 Stepper Motor Replacement (Figure 4-12)

1. Install the steel belt tensioner (E) in the frame.
2. Install the stepper motor and bracket on the frame with screws (D).
3. Install screws (C) to secure the steel belt. Use flat-tipped tweezers to lift the steel belt above the screw posts.
4. Connect the motor circuit lead wires (A) to the motor control board.
5. Install the track 00 sensor and jacket lifter spring (Section 4.3.9):
6. Install the front panel (Section 4.3.6), and the subframe (Section 4.3.8).
7. Install the FDD control board (Section 4.3.4), then install the FDD unit in the case (Section 4.3.2).

4.3.13 Head Carriage Removal (Figure 4-13)

1. Remove the FDD unit from the case (Section 4.3.1), and remove the FDD control board (Section 4.3.3).
2. Remove the subframe unit (Section 4.3.7) and the track 00 sensor and jacket lifter spring (Section 4.3.9).
3. Remove the stepper motor (Section 4.3.11).
4. Disconnect the head lead wires from the clamp (A) on the main frame and remove slide shaft plate (B).
5. Tilt the carriage downward on the stepper motor side and lift the head assembly from the frame.
6. Turn the steel belt tensioner (C) 90 degrees and release it from the frame.

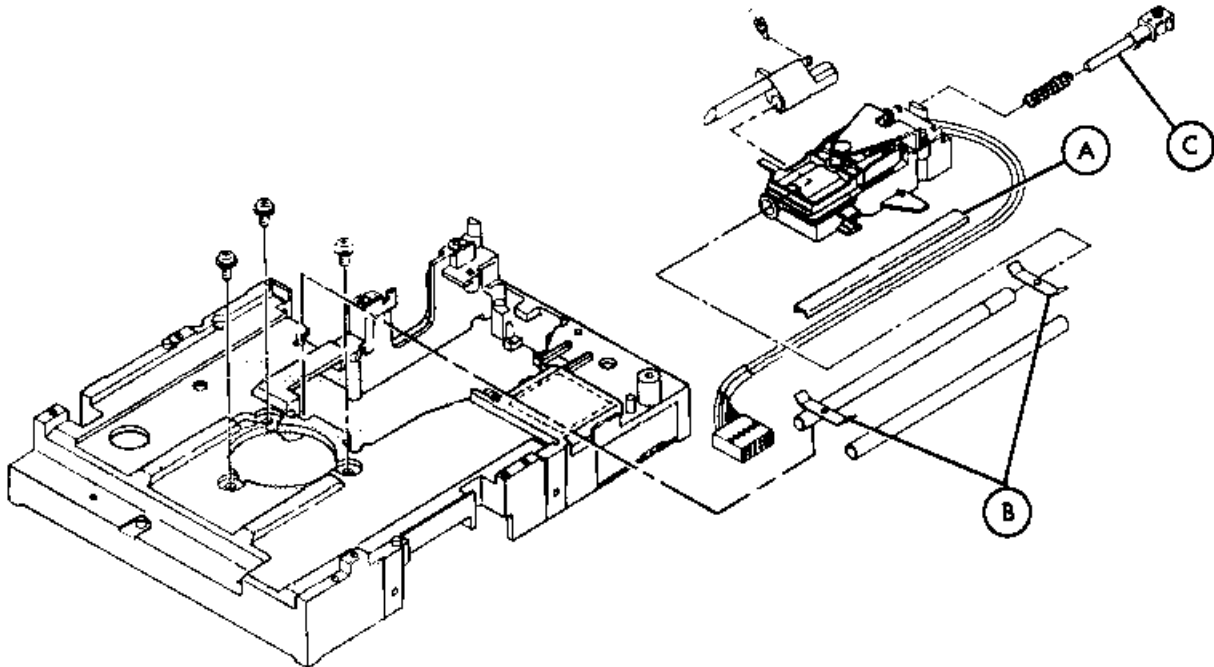

FIGURE 4-13. HEAD CARRIAGE REMOVAL/REPLACEMENT

4.3.14 Head Carriage Replacement (Figure 4-13)

1. Install the steel belt tensioner and tension spring (C).
2. Insert the slide shaft into the jacket lifter and install the assembly on the carriage.
3. Install the carriage assembly and the slide shaft fixing plate (B) on the frame.
4. Connect the head lead wires at clamp (A) on the main frame, making certain that there is ample slack in the wires to allow the head to move freely between the inner and outer tracks. Apply Cemedine adhesive to the wires at the clamping point.
5. Install the stepper motor (Section 4.3.12).
6. Install the jacket lifter spring and track 00 sensor (Section 4.3.10) and the subframe unit (Section 4.3.8). The arm of the upper carriage must be on the collet lever.
7. Install the FDD control board (Section 4.3.4), then install the FDD unit in the case (Section 4.3.2).

4.3.15 Motor Control Board and Drive Motor Removal (Figure 4-14)

1. Remove the FDD unit from the case (Section 4.3.1), and remove the FDD control board (Section 4.3.3).
2. Remove the subframe unit (Section 4.3.7).
3. Disconnect track 00 connector P5 (A) and stepper motor connector P6 (B) from the motor control board.
4. Remove motor securing screws (C) and dismount the motor unit. Handle the motor with care so that the spindle is not damaged.

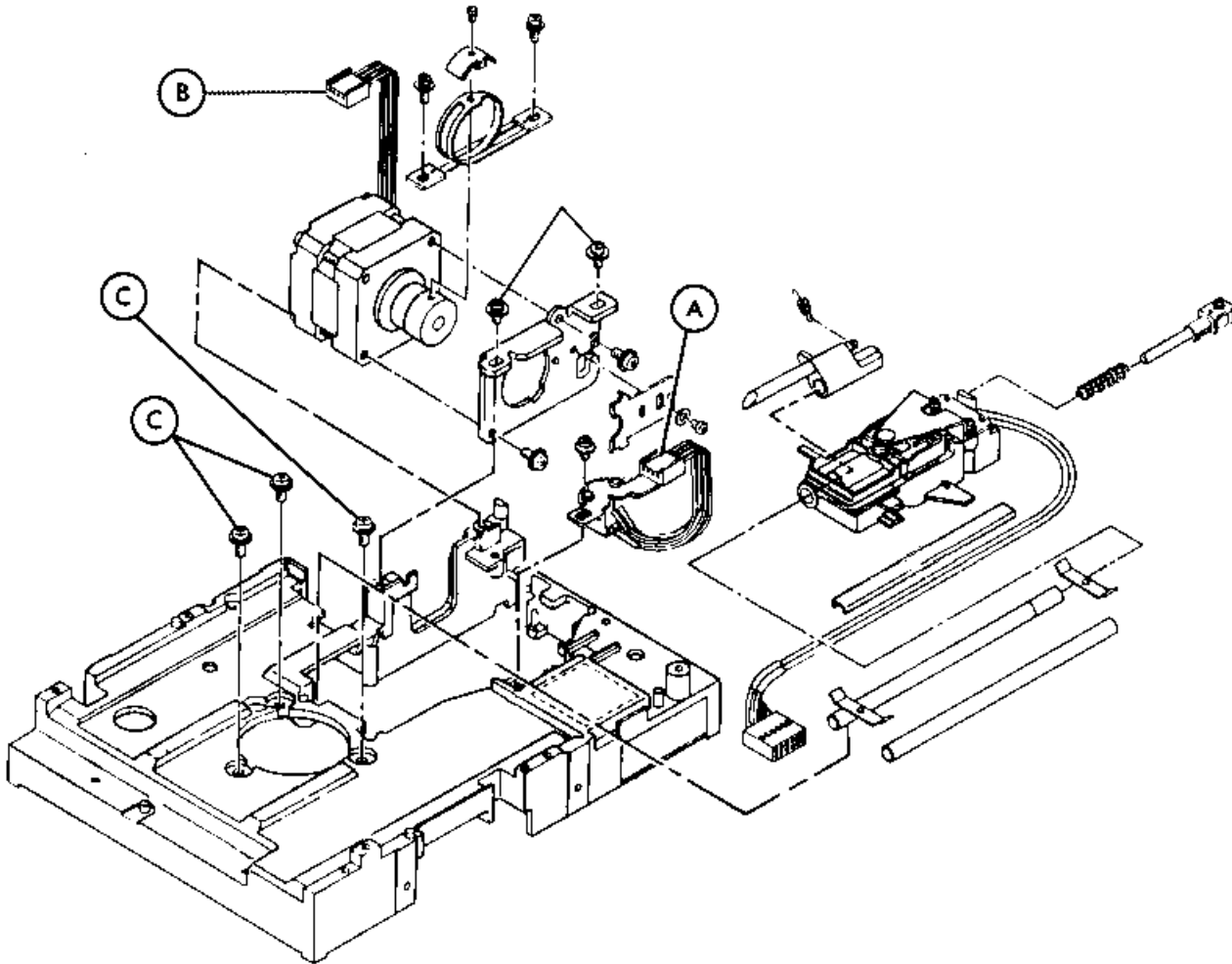

FIGURE 4-14. MOTOR CONTROL BOARD REMOVAL/REPLACEMENT

4.3.16 Motor Control Board and Drive Motor Replacement (Figure 4-14)

1. Install the drive motor with screws (C)
2. Connect P5-J5 (A) and P6-J6 (B) on the motor control board.
3. Install the subframe (Section 4.3.8) and the FDD control board (Section 4.3.4).
4. Adjust the motor speed. (Refer to Section 5.3.1.)

4.4 KEYBOARD DISASSEMBLY AND ASSEMBLY

4.4.1 Keyboard Case Removal (Figure 4-15)

1. Disconnect the keyboard cable from the main unit and the keyboard.
2. Turn the keyboard upside down and remove screws (A) from the lower case. Lift the case straight up to remove.

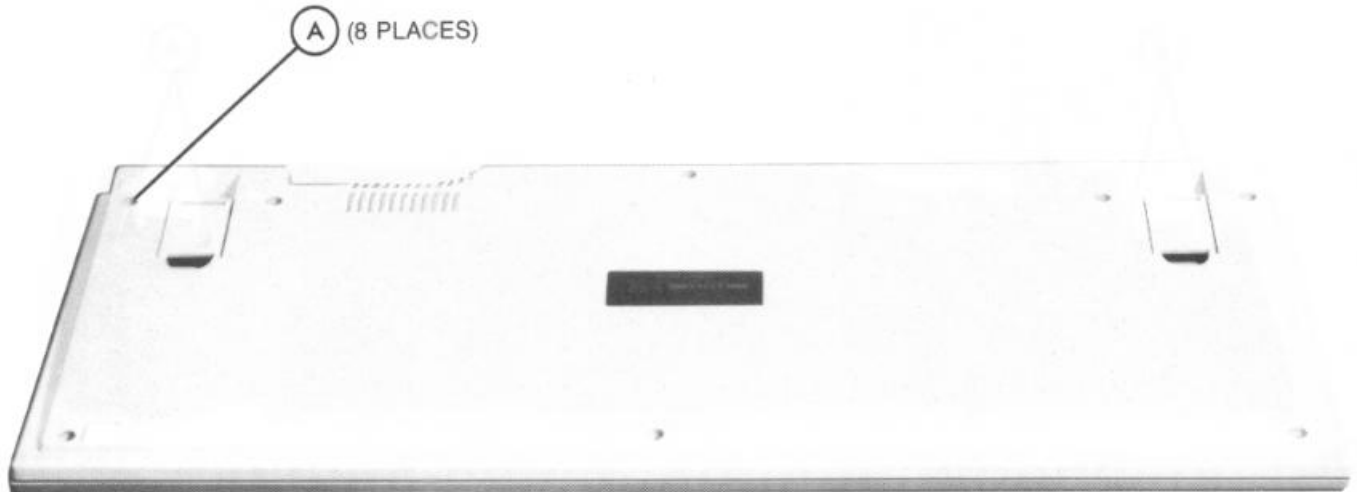

FIGURE 4-15. KEYBOARD CASE REMOVAL/REPLACEMENT

4.4.2 Keyboard Case Replacement (Figure 4-15)

1. Install the keyboard case with screws (A) and install the keyboard cable.

4.4.3 Keyboard Circuit Board Removal (Figure 4-16)

1. Remove the keyboard case (Section 4.4.1).
 2. Remove four screws (A) and the accompanying brackets.
 3. Remove 11 screws from the circuit board and carefully lift the board to remove.
-

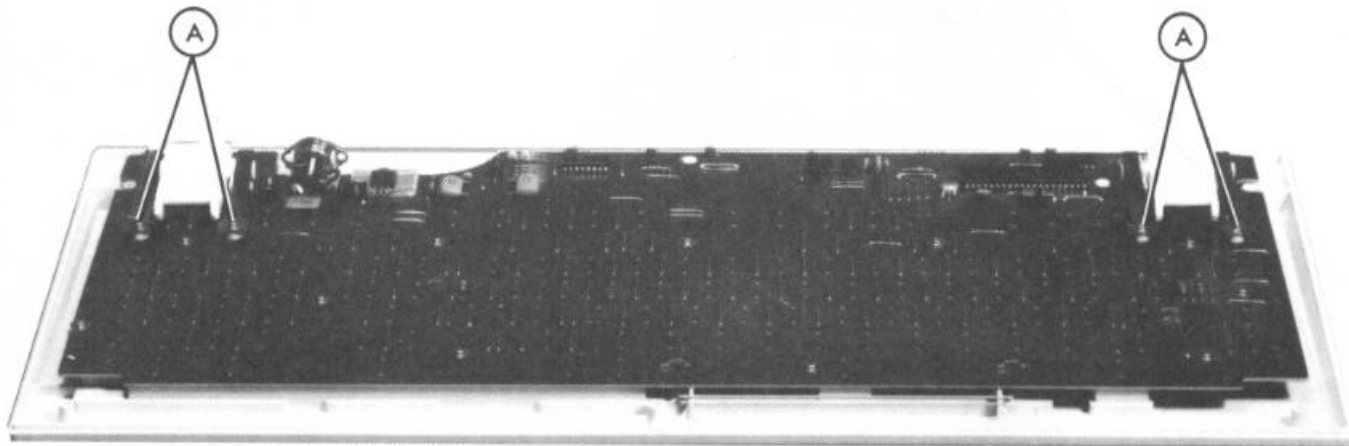

FIGURE 4-16. KEYBOARD CIRCUIT BOARD REMOVAL/REPLACEMENT

4.4.4 Keyboard Circuit Board Replacement (Figure 4-16)

1. Install the circuit board with 11 screws, and install the four brackets with screws (A).
2. Install the keyboard case (Section 4.4.2).

4.5 MONITOR DISASSEMBLY AND ASSEMBLY

DANGER

THE MONITOR IN THIS SYSTEM INCLUDES HIGH VOLTAGE CIRCUITRY. DISCONNECT THE MONITOR FROM THE AC OUTLET BEFORE DISASSEMBLY. IMMEDIATELY AFTER REMOVING THE MONITOR CASE, USE A SCREWDRIVER OR SIMILAR DEVICE TO SHORT THE ANODE OF THE CRT TO THE CONDUCTIVE CABLE ON THE TUBE. DO NOT ATTEMPT TO DISCHARGE THE ANODE BY CONNECTING IT WITH ISOLATED PARTS OF THE MONITOR, AS THIS MAY PRODUCE A SHOCK HAZARD.

4.5.1 Monitor Upper Case Removal (Figure 4-17)

1. Disconnect the monitor from the AC outlet and from the main unit.
2. Remove two screws (A) from the rear case and gently lift the case to remove.

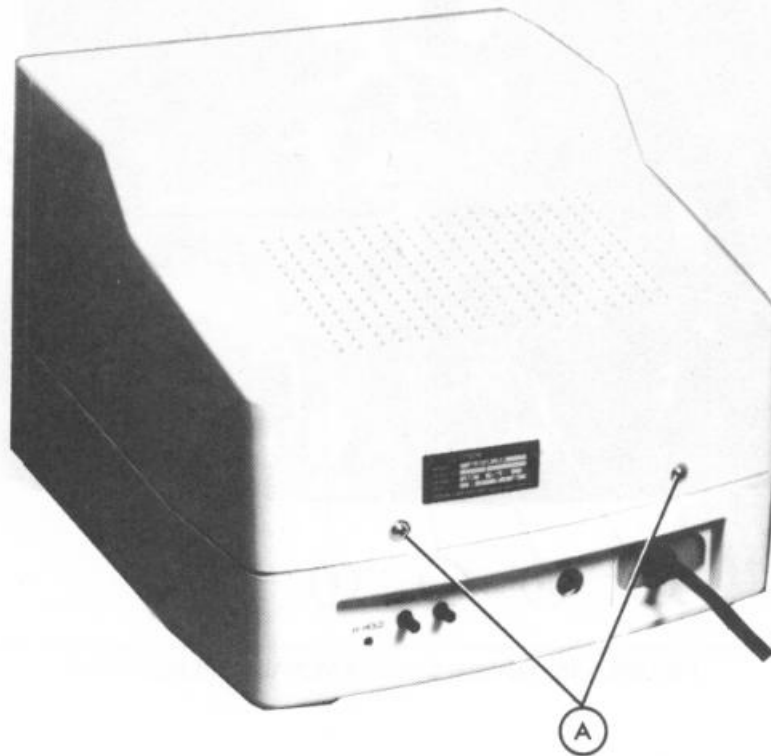

FIGURE 4-17. MONITOR UPPER CASE REMOVAL/REPLACEMENT

4.5.2 Monitor Upper Case Replacement (Figure 4-17)

1. Position the edge of the case in the bezel at the front of the monitor. Gently push down to lock the case tabs under the edge of the bezel.
2. Insert two screws (A) to secure the case.

4.5.3 Monitor Lower Case Removal (Figure 4-18)

1. Remove the upper monitor case (Section 4.5.1).
2. Remove socket (A) and anode cap (B) from the CRT.
3. Remove cable tie (C) and disconnect the CRT yoke at connector (D).
4. Disconnect the AC power switch at (E) and remove cable tie (F).
5. Disconnect the black ground wire (G) and LED power indicator (H).
6. Remove five screws (J) and separate the CRT and bezel from the lower case. Place the CRT face down on a level surface.

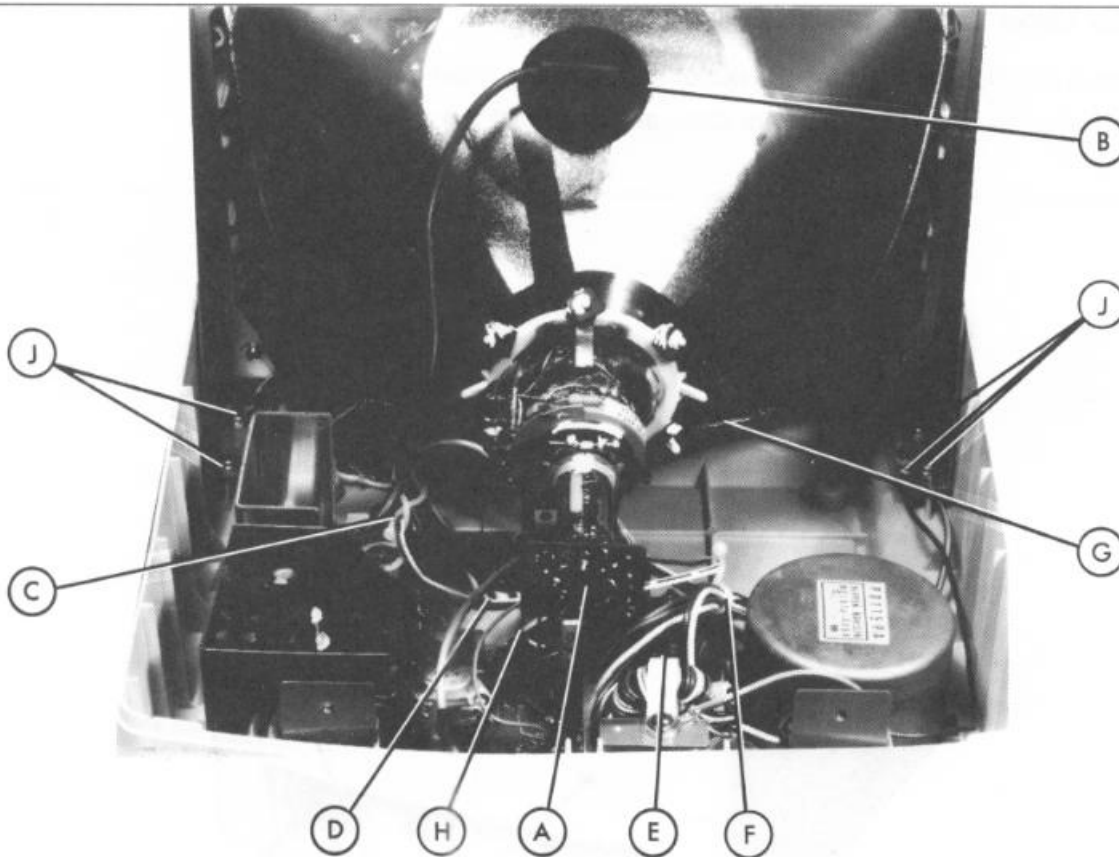

FIGURE 4-18. LOWER CASE REMOVAL/REPLACEMENT

4.5.4 Monitor Lower Case Replacement (Figure 4-18)

1. Position the lower case with the upper case and bezel and install five screws (J).
2. Connect ground strap (G) and LED power indicator (H).
3. Connect the AC power switch at (E) and install cable tie (F).
4. Install the CRT yoke at connector (D) and install cable tie (C).
5. Install socket (A) at the rear of the CRT and install the anode cap (B).
6. Install the upper monitor case (Section 4.5.2).

4.5.5 Power Transformer Removal (Figure 4-19)

1. Remove the upper case (Section 4.5.1) and lower case (Section 4.5.3).
2. Disconnect transformer connector (A) from CRT circuit board (B).
3. Remove four screws (C) and lift the transformer assembly.

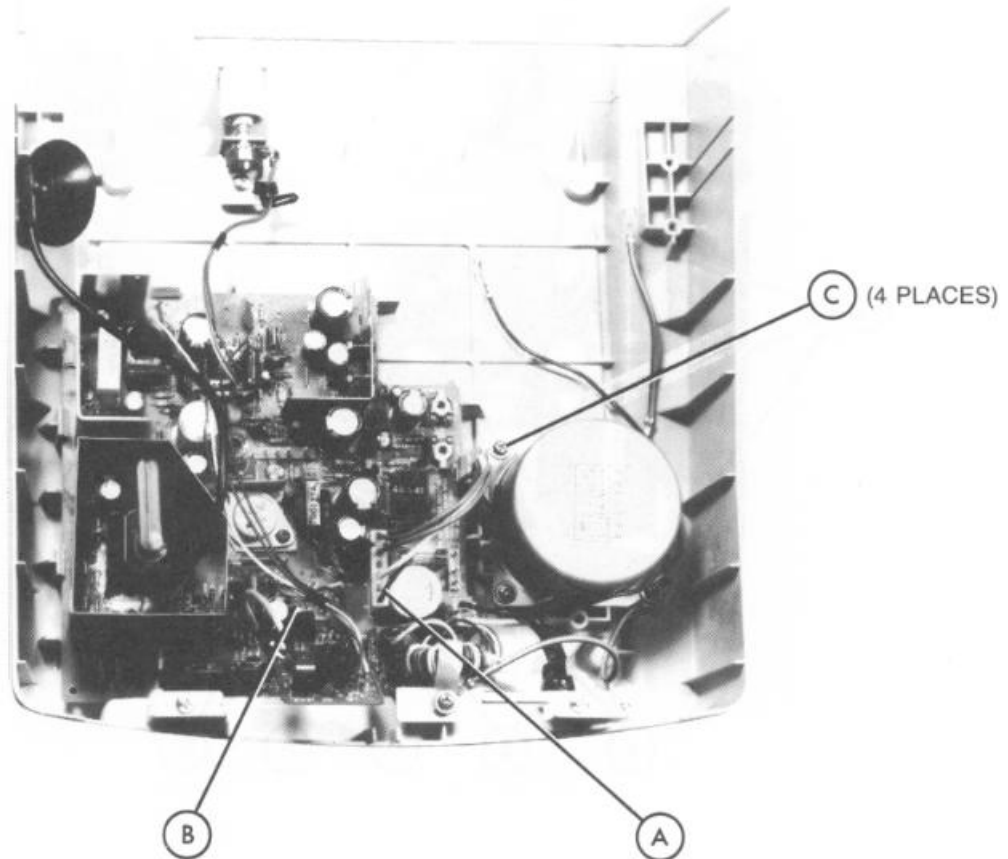

FIGURE 4-19. POWER TRANSFORMER REMOVAL/REPLACEMENT

4.5.6 Power Transformer Replacement (Figure 4-19)

1. Position the transformer connector (A) on the lower case and insert four screws (C).
2. Connect the transformer and the CRT circuit board (B).
3. Install the lower case (Section 4.5.4).

4.5.7 Monitor Circuit Board Removal (Figure 4-20)

1. Remove the lower case (Section 4.5.3).
2. Disconnect transformer connector (A) from circuit board (B); disconnect AC connector (C), video input cable (D), and brightness control (E).
3. Remove two screws (F) and press outward on tabs (G) to remove the circuit board.

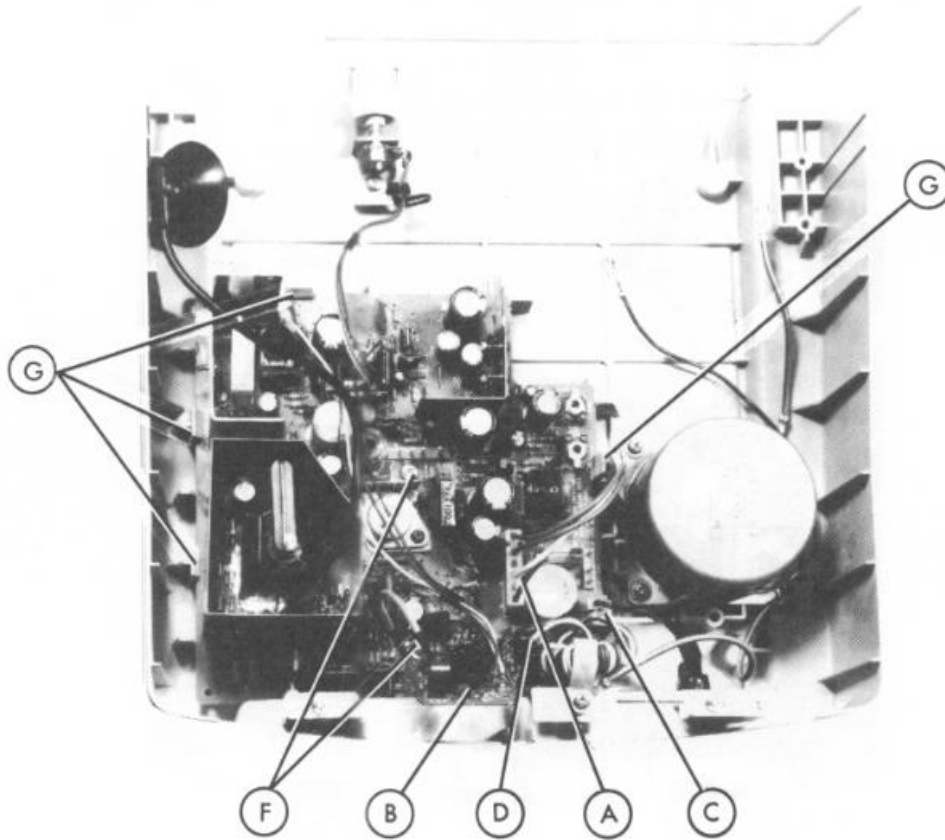

FIGURE 4-20. MONITOR CIRCUIT BOARD REMOVAL/REPLACEMENT

4.5.8 Monitor Circuit Board Replacement (Figure 4-20)

1. Press back on tabs (G) while installing circuit board (B). Secure the board with two screws (F).
2. Install transformer connector (A), AC input (C), video cable (D), and brightness control (E).
3. Install the lower case (Section 4.5.4).

4.5.9 Brightness Control Removal (Figure 4-21)

1. Remove the lower case (Section 4.5.3).
2. Disconnect the brightness control (A) from CRT circuit board (B).
3. Remove screw (C) and lift the brightness control to remove.

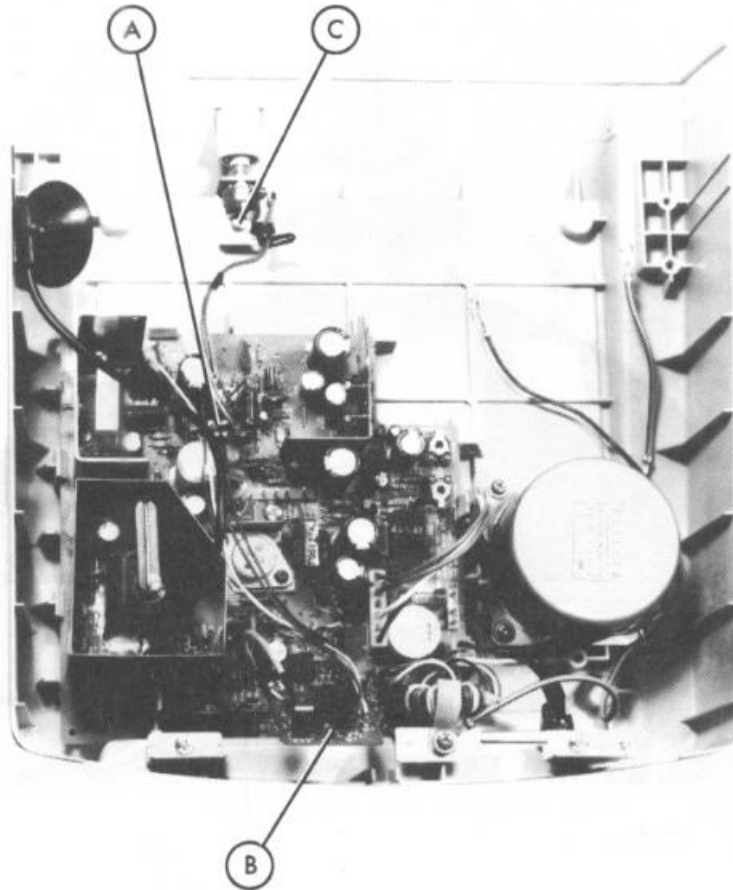

FIGURE 4-21. BRIGHTNESS CONTROL REMOVAL/REPLACEMENT

4.5.10 Brightness Control Replacement (Figure 4-21)

1. Install the brightness control (A) with screw (C).
2. Connect the CRT circuit board (B) to the brightness control.
3. Install the lower case (Section 4.5.4).

4.5.11 Power Switch Removal (Figure 4-22)

1. Remove the lower case (Section 4.5.3).
2. Remove tie (A) and remove two screws (B) from the switch bracket. Remove the bracket by sliding it backward.

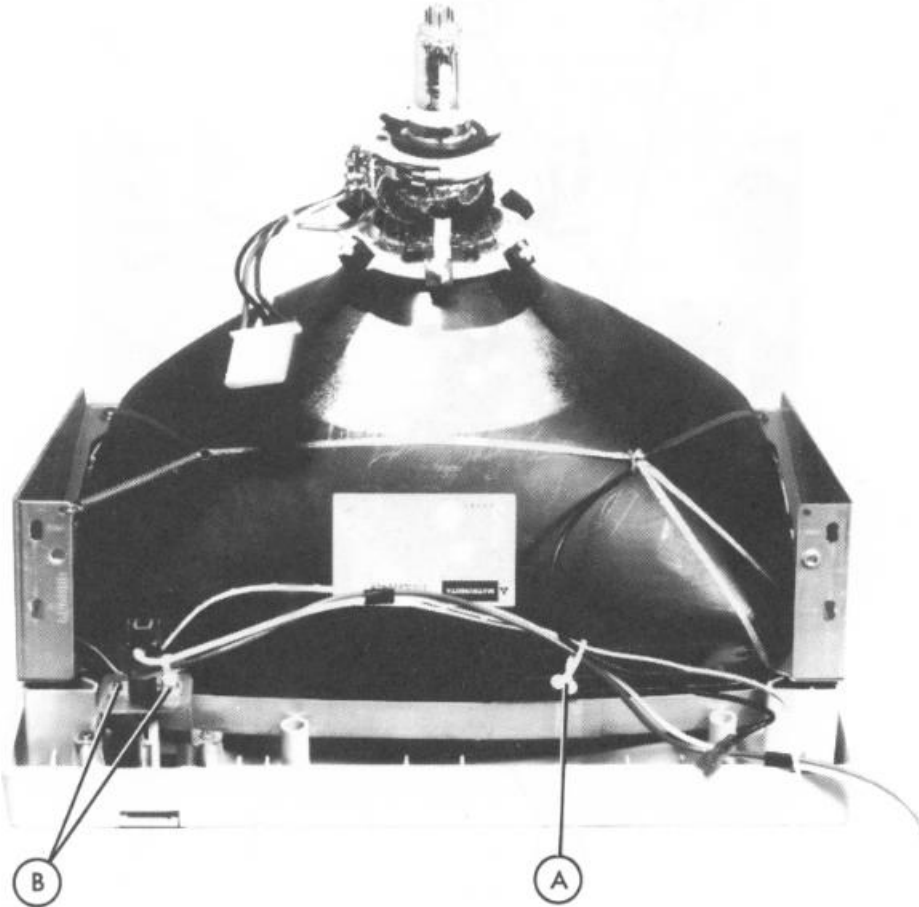

FIGURE 4-22. POWER SWITCH REMOVAL/REPLACEMENT

4.5.12 Power Switch Replacement (Figure 4-22)

1. Install the switch assembly and attach two screws (B) and cable tie (A).
2. Install the lower case (Section 4.5.4).

4.5.13 CRT Removal (Figure 4-23)

DANGER

MAKE CERTAIN THE CRT IS DISCHARGED BEFORE PERFORMING ANY OF THE FOLLOWING PROCEDURES. DURING REMOVAL AND REPLACEMENT, HOLD THE CRT WITH THE FACE OF THE SCREEN POINTED AWAY FROM YOUR BODY. DO NOT SUPPORT THE TUBE BY THE NECK.

1. Remove the upper monitor case (Section 4.5.1).
2. Remove the lower monitor case (Section 4.5.3).
3. Remove four screws (A) and carefully lift the CRT from the front bezel.

WARNING

Handle the tube with care to avoid scratching, and do not subject the CRT to pressure or shock during removal or replacement. Use only the approved replacement CRT.

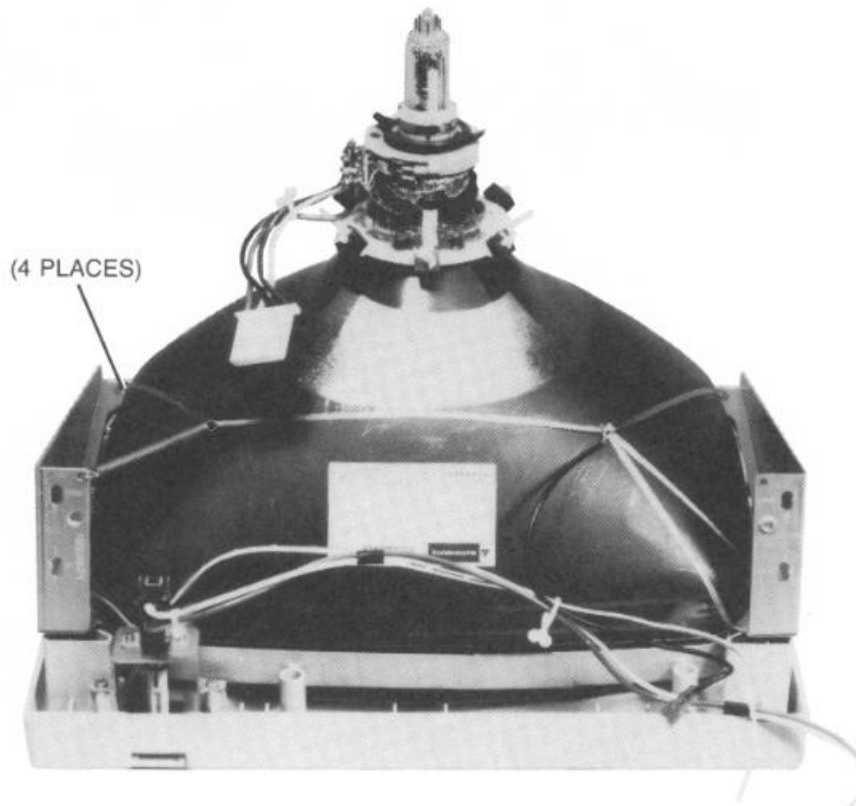

FIGURE 2-23. CRT REMOVAL/REPLACEMENT

4.5.14 CRT Replacement (Figure 4-23)

1. Position the CRT in the front bezel and install four screws (A).
2. Install the lower case (Section 4.5.4).
3. Install the upper case (Section 4.5.2).