

MAINTENANCE MANUAL

YD-380

HALF HEIGHT, HIGH DENSITY, DOUBLE SIDED

5.25 INCH FLEXIBLE DISK DRIVE

Contents of this manual may be changed without notice.
Check the revision number when placing an order.

September 1983

FDL-523006 REV. A

Revisions

Date		Rev.	Description	Revised Pages
September	1983	A	First Edition	

Note: In this publication

(1) The YD-380 may be referred to as simply a "drive".

(2) The 5.25 inch flexible disk may be referred to as simply a disk.

YD-380 Maintenance Manual

TABLE OF CONTENTS

	Page
1.0 INTRODUCTION	1
2.0 MAINTENANCE TOOLS AND TEST EQUIPMENT	1
2.1 Maintenance Tool List	1
2.2 Maintenance Supplies List	2
2.3 Test Equipment	2
2.4 Exerciser	2
3.0 PREVENTIVE MAINTENANCE	3
3.1 General	3
3.2 Visual Check	3
3.3 Cleaning	3
4.0 SERVICE CHECKS, REPLACEMENT AND ADJUSTMENT	4
Maintenance Level 1	
4.1 PWB	5
4.2 Index Sensor Assembly	6
4.3 Track 00 Sensor Assembly	9
4.4 Write Protect Sensor Assembly	11
4.5 Media Sensor Assembly	12
4.6 In Use Lamp Assembly	14

TABLE OF CONTENTS

	Page
Maintenance Level 2	
4.7 Carrier Assembly	15
4.8 Index Lamp Assembly (on Motor Control PWB)	16
4.9 Drive Motor Assembly (on Motor Control PWB)	17
4.10 Head Load Solenoid	18
4.11 Front Lever	21
4.12 Front Bezel	22
4.13 Stepper Assembly	23
4.14 Head/Carriage Assembly	24
5.0 PARTS/ASSEMBLIES PHYSICAL LOCATIONS	30
6.0 TEST POINT/CONNECTOR PIN ASSIGNMENTS	35
7.0 SPARE PARTS LIST	38
8.0 SCHEMATIC DIAGRAMS	39
9.0 EXPLODED VIEW	42
10.0 USING A CLEANING DISK	43

1.0 INTRODUCTION

This manual describes the maintenance and operation of the Y-E DATA YD-380 two sided, high density, 5.25 inch Floppy Disk Drive. Included is information on service checks, removal and replacement procedures, and also adjustment instructions for customers' engineers.

2.0 MAINTENANCE TOOLS AND TEST EQUIPMENT

The following tables list the maintenance tools, maintenance supplies, test equipment and exerciser for the YD-380.

2.1 Maintenance Tools List

TOOL	Y-E DATE P/N
Phillips Screwdriver (for M3)	141034-01
Phillips Screwdriver (for M2.6)	141627-01
Flat Head Screwdriver	141035-01
Cutters	141039-01
Needle Nose Pliers	141040-01
Tweezers	141042-01
CE Disk	145173-01
Cleaning Disk	145174-01
Hex Wrench 1.27 mm	140266-03
Hex Wrench 1.5 mm	140266-01

2.2 Maintenance Supplies

Supplies	Y-E DATA P/N
Tie Wrap (TY-23M, Kitagawa)	031005-01

2.3 Test Equipment

Test Equipment
Multimeter
Electronic Counter*
Oscilloscope*

* For use at Maintenance Level 2

2.4 Exerciser

Equipment	Y-E DATA P/N
Exerciser	YD-164T

3.0 PREVENTIVE MAINTENANCE

3.1 General

In a reasonably dust-free environment, preventive maintenance should be performed on the YD-380 every two years. This includes a visual check and cleaning.

In a dirty environment, the interval between maintenance checks should be shortened.

3.2 Visual Check

Visual inspection should be the first step in any maintenance operation. Always look for corrosion, dirt, wear, binds, and loose connections. Checking for these problems can help reduce downtime later.

3.3 Cleaning

All cleaning of the YD-380 should be performed carefully. Remove gently all dust deposits with lint free gauze or an applicator moistened with isopropyl alcohol.

CAUTION

The head/carriage assembly is adjusted and tested at the factory and is not field serviceable. Do not, for any reason, attempt to repair this component.

Check Points for Preventive Maintenance

Part	Check	Correction
Frame Connectors	Dirt and dust on the connectors, sensors, other areas.	Clean
Sensors Misc.	Loose Screws	Tighten

4.0 SERVICE CHECKS, REPLACEMENTS AND ADJUSTMENTS

This chapter contains detailed maintenance procedures for the assemblies listed below. Note that the list is separated into two maintenance levels:

Level 1: Can be performed without special training or tools.

Level 2: Special training and tools required.

Level 1

- 4.1 PWB
- 4.2 Index Sensor
- 4.3 Track 00 Sensor
- 4.4 Write Protect Sensor
- 4.5 Media Sensor
- 4.6 In Use Lamp

Level 2

- 4.7 Carrier
- 4.8 Index Lamp (on Motor Control PWB)
- 4.9 Drive Motor (on Motor Control PWB)
- 4.10 Head Load Solenoid
- 4.11 Front Lever
- 4.12 Front Bezel
- 4.13 Stepper
- 4.14 Head/Carriage Assembly

Note: Refer to Chapter 5 for Parts/Assemblies Locations,
Chapter 6 for Test Points/Connector Pin Assignments and
Chapter 9 for Exploded View.

[Level 1]

4.1 PWB (Refer to Chapter 5, Figure 1)

4.1.1 PWB Replacement

1. Disconnect the 4 connectors (J₁, J₂, J₃, J₄) from the PWB.
2. Remove the four screws securing the PWB to the frame casting.
3. Remove the PWB.
4. For reinstallation, reverse the above procedure.

Note: Make sure to mount the PWB below the carrier cover when reinstalling.

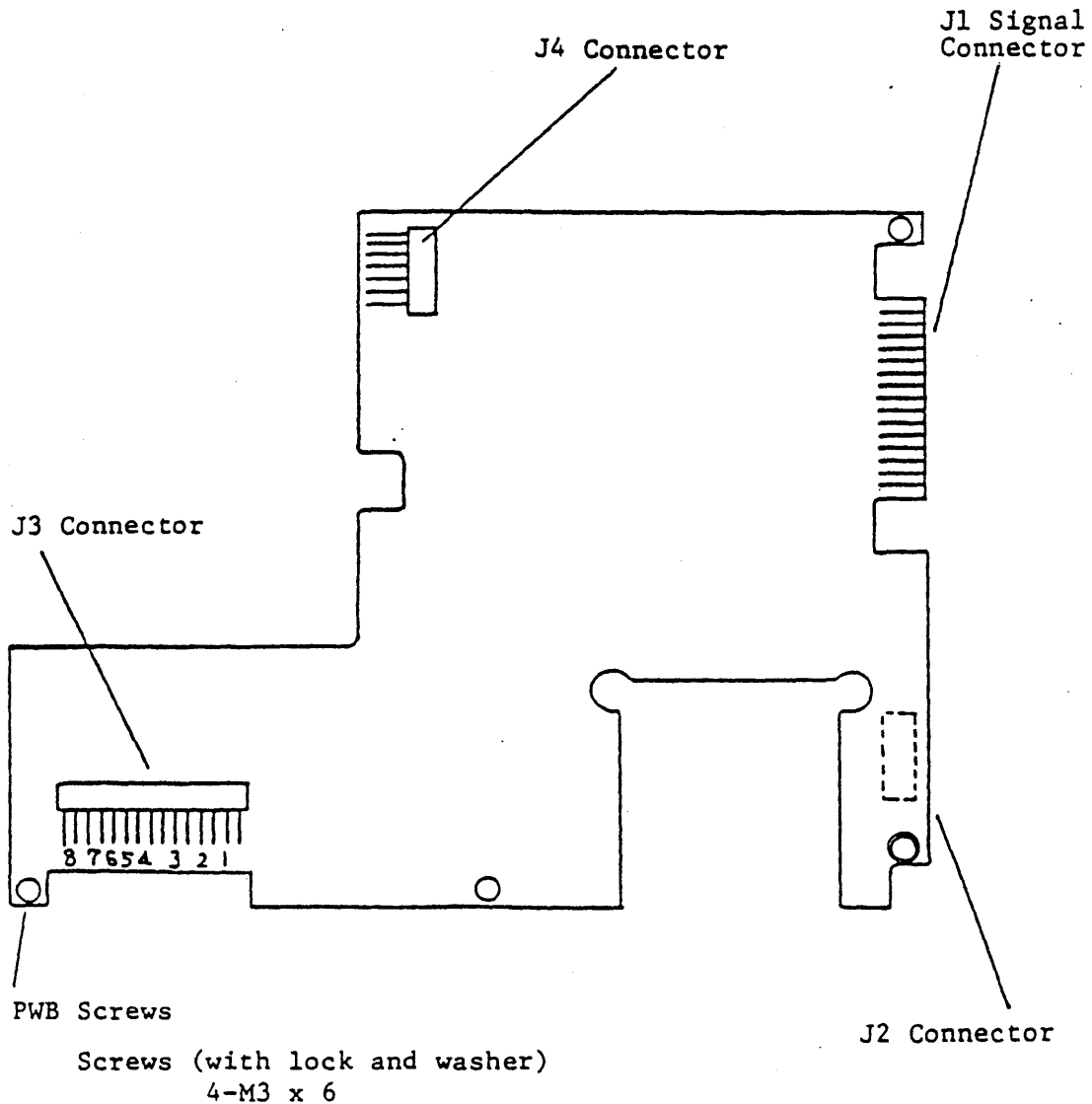

Figure 4.1.1

4.2 Index Sensor Assembly (Refer to Chapter 5, Figure 3)

4.2.1 Service Check

1. Power up the drive.
2. Without inserting a disk, move the lever to lock position and check for 0 to 0.5 V between the PWB connector J3 Pin All and G (GND). Next, insert a disk and close the door; the voltage at the same points should be 2.5 to 5.25 V.

4.4.2 Replacement

1. Remove the PWB (Refer to 4.1)
2. Remove J3 connector housing 6. (Refer to Page 9, figure 4.2.2)
3. Take out the carrier cover screws and remove the carrier cover.
4. Lift up the lead clamps slightly and pull out the leads.
5. Remove the In Use Lamp.
6. Take out the screws for the front lever and carrier assembly, and remove the front lever and carrier assembly.
7. Take out the screws to the Write Protect Sensor assembly, and as shown in figure 4.4.1, remove the write protect sensor assembly by pushing in the direction indicated.

CAUTION

When clamping the leads, be careful not to damage the lead insulation.

8. For reinstallation, reverse the above procedure.
9. Perform a service check. (See 4.1.1)

Note: Make sure the front edge of the carrier plate spring arm securing the Ready/Off plate does not come in contact with the leads.

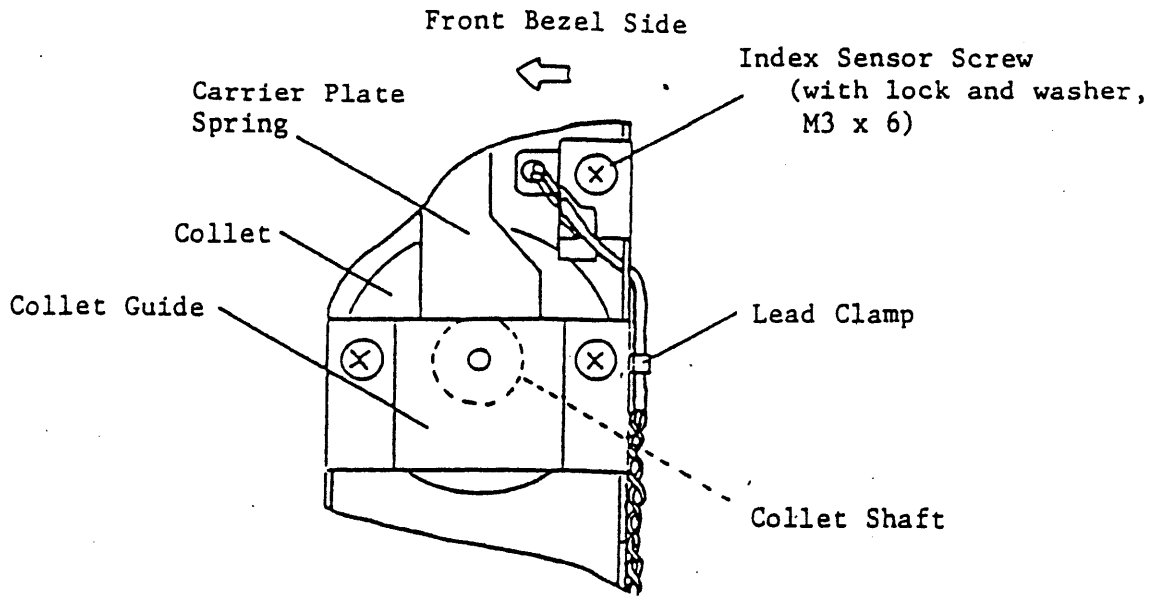

Figure 4.2.1

J3 Connector Housing Assignment

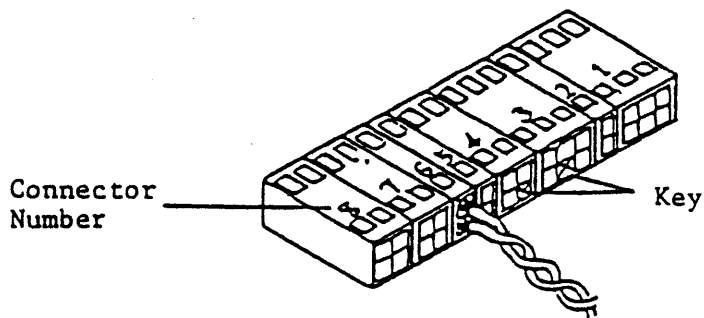

Figure 4.2.2

Connector No.	Part
1	Stepper
2	Head Load Solenoid
3	Drive Motor
4	Write Protect Sensor
5	In Use Lamp
6	Index Sensor
7	Track 00 Sensor
8	Media Sensor

4.2.3 Adjustment

1. Loosen the Index Sensor screws one quarter turn.
2. Power up the drive.
3. Connect an oscilloscope to the PWB test points 1A, 1B, 3. Connect channel 1 to PWB TP 1A, channel 2 to TP 1B, and connect the external scope trigger to TP3.

Set the oscilloscope controls as follows:

INPUT COUPLING MODE	AC
VERT MODE	ADD
INVERT (CH 2)	ON
TIME/DIV	0.1 ms
VOLTS/DIV (CH1, CH2)	100 mV

4. Insert a CE Disk and turn the front lever to lock position.
5. Load the read/write heads against the disk and step the head/carriage assembly to track 2. Adjust the sensor position until the timing between the start of the sweep (index signal from TP3) and the first part of the index burst (TP 1A, TP 1B) is within -600 to $1400 \mu\text{s}$.

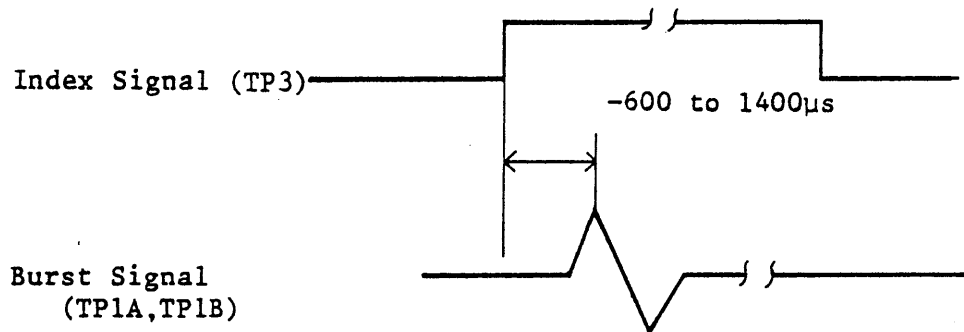

Figure 4.2.3

Note: To delay the Index Burst, move the sensor towards the front bezel (see Page 9, figure 4.2.1).

6. Verify that the timing between the start of the sweep and the first peak of the index burst is between -600 to 1400 μ s at side 0 and 1, track 02 and track 68.

4.3 Track 00 Sensor Assembly (Refer to Chapter 5, Figure 4)

4.3.1 Service Check 1, Track 00 Sensor

1. Power up the drive. (Resets memories in PWB)
2. Step the head/carriage assembly to a position near the inner stop.
3. Check the following:
 - a. Track 00 Lamp:
The voltage across PWB J3-A12 and G (GND) should be between 1.0 and 1.7 V.
 - b. Track 00 Sensor:
The voltage across PWB J3-A13 and G (GND) should be between 0 and 0.5 V.
4. Power the drive down and up again. (Resets PWB memories)
5. Check the following:
 - a. Track 00 Sensor:
The voltage across PWB J3-A13 and G(GND) should be between 2.5 and 5.25 V.

Service Check 2, Track 00 Sensor Position Check

1. With power off, move the head/carriage assembly all the way to the outer stop.
2. Power up the drive.
3. When power is applied, the head/carriage assembly should move inwards slightly. The Track 00 signal (J1-26) should be at Low level (0 to 0.4 V).
4. Move the head/carriage assembly five steps inward and one step outward. The voltage should change to a High level of 2.4 to 5.25 V.

4.3.2 Removal and Replacement

1. Remove the PWB (See 4.1).
2. Remove J3 connector housing 7. (Refer to page 9, figure 4.2.2)
3. Cut the J3 cable tie wrap with cutters and remove the Track 00 sensor leads from the miniclamp.

CAUTION

Be careful not to damage the leads when cutting the tie wrap.

4. Take out the Track 00 sensor assembly screw and remove the assembly.

Note: Do not remove the sensor mounting screw or the adjustment screw.

5. For reinstallation, reverse the above procedure.

Note: To attach the Track 00 sensor, push it against the frame stop and tighten the screw.

6. Perform service checks 1 and 2.

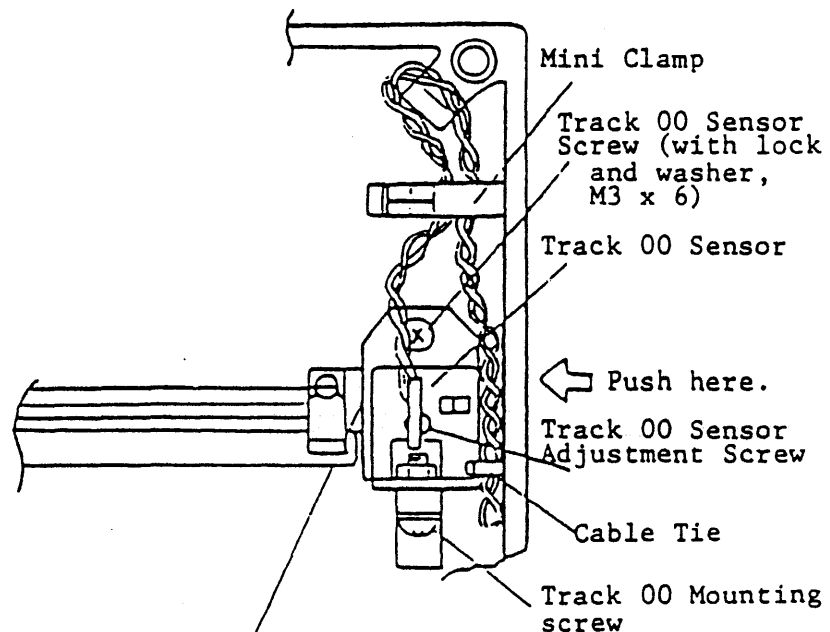

Figure 4.3.1

Stop

4.4 Write Protect Sensor (See Chapter 5, Figure 3)

4.4.1 Service Check

1. Power up the drive.
2. Check the following with no disk in the drive.
 - a. Write Protect Lamp:
The voltage across J3-A8 and G (GND) should be between 1.0 and 1.7 V.
 - b. Write Protect Sensor:
The voltage across J3-A9 and G (GND) should be between 0 and 0.5 V.
3. Check the following with a write protected disk (a disk with a write protect seal over the write protect notch) in the drive and the front lever in lock position.
 - a. Write Protect Sensor:
The voltage across J3-A9 and G (GND) should be between 2.5 and 5.25 V.

4.4.2 Removal and Replacement

1. Remove the PWB (See 4.1).
2. Remove housing 4 from the J3 connector. (See page 9, figure 4.2.2).
3. Remove the carrier cover screws and remove the carrier cover.
4. Lift the tabs from the carrier and write protect lead clamps (two locations) and remove the leads.
5. Remove the In Use Lamp
6. Take out the screws for the front lever and carrier assembly, and remove the front lever and carrier assembly.

7. Take out the screws to the write protect sensor assembly, and as shown in figure 4.2.2, remove the write protect sensor assembly by pushing in the direction indicated.

CAUTION

When removing or clamping leads, be careful not to damage the lead insulation.

8. For reinstallation, reverse the above procedure.
9. Perform a service check. (See 4.4.1)

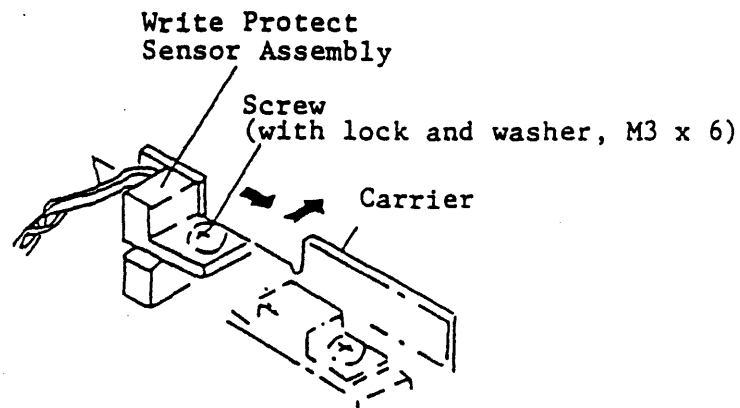

Figure 4.4.1

4.5 Media Sensor Assembly (Refer to Chapter 5, figure 3)

4.5.1 Service Check

1. Power up the drive.
2. Perform the following with no disk in the drive.
 - a. Check for 1.0 to 1.7 V across PWB J3-A14 and G (GND).
 - b. Check for 0 to 0.5 V across J3-A15 and G (GND).
3. Insert a disk and check the following.
 - a. Check for 2.5 to 5.25 V across J3-A15 and G (GND).

4.5.2 Removal and Replacement

1. Remove the PWB (See 4.1).
2. Remove J3 connector housing 8. (See Page 9, figure 4.2.2)
3. Remove the carrier cover screws and the carrier cover.
4. Remove the In Use Lamp.
5. Remove the media sensor assembly screws and the media sensor assembly.
6. For reinstallation, reverse the above procedure.
7. Perform a service check. (See 4.5.1)

Note: The media sensor assembly should be attached perpendicularly to the frame.

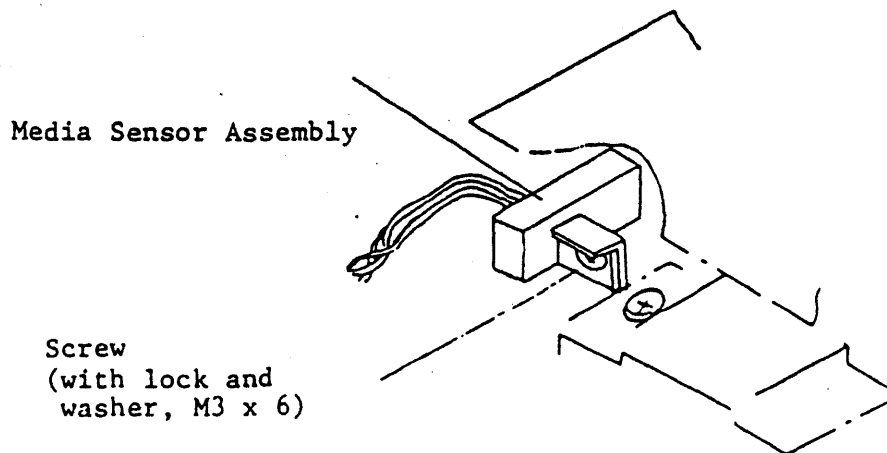

Figure 4.4.2

4.6 In Use Lamp (Refer to Chapter 5, Figure 5)

4.6.1 Service Check

1. Power up the drive.
2. Set interface signal DRIVE SELECT 0 to Low level, and install a shorting plug on shorting pin DS 0.
3. The lamp should light up.

Note: When the lamp is lit, the voltage across J3-A10 and G (GND) should be between 1.0 and 2.0 V.

4.6.2 Removal and Replacement

1. Remove Housing 5 from the PWB J3 Connector.
2. Remove the In Use Lamp assembly screws and remove the In Use Lamp assembly.
3. For reinstallation, reverse the above procedure.
4. Perform a service check. (See 4.6.1)

[Level 2]

4.7 Carrier Assembly (See Chapter 5, figure 3)

4.7.1 Removal and Replacement

1. Remove the PWB. (See 4.1)
2. Remove the carrier cover screws and remove the carrier cover.
3. Lift the tabs for the clamps on the carrier assembly and remove connector housings 1, 2, 3 and 7.
4. Remove the front lever screws and remove the front lever.
5. Remove the carrier assembly screws and remove the carrier assembly by pushing towards the rear of the drive. (See page 18, figure 4.7.1)
6. For reinstallation, reverse the above procedure.

<p>Notes: 1) Make sure that the bosses on the carrier fit correctly into the matching frame holes when reattaching the carrier.</p> <p>2) Make sure that the Ready/Off plate is below the head arm hanger when reattaching the carrier assembly. (See page 24, figure 4.10.1)</p>

4.8 Index Lamp Assembly

4.8.1 Service Check

1. Power up the drive.
2. Check that the voltage across the PWB J3-A7 and G (GND) is between 1.0 and 1.7 V.

4.8.2 Removal and Replacement

1. Removal procedure is included in the section on the drive motor assembly (refer to 4.9.2)

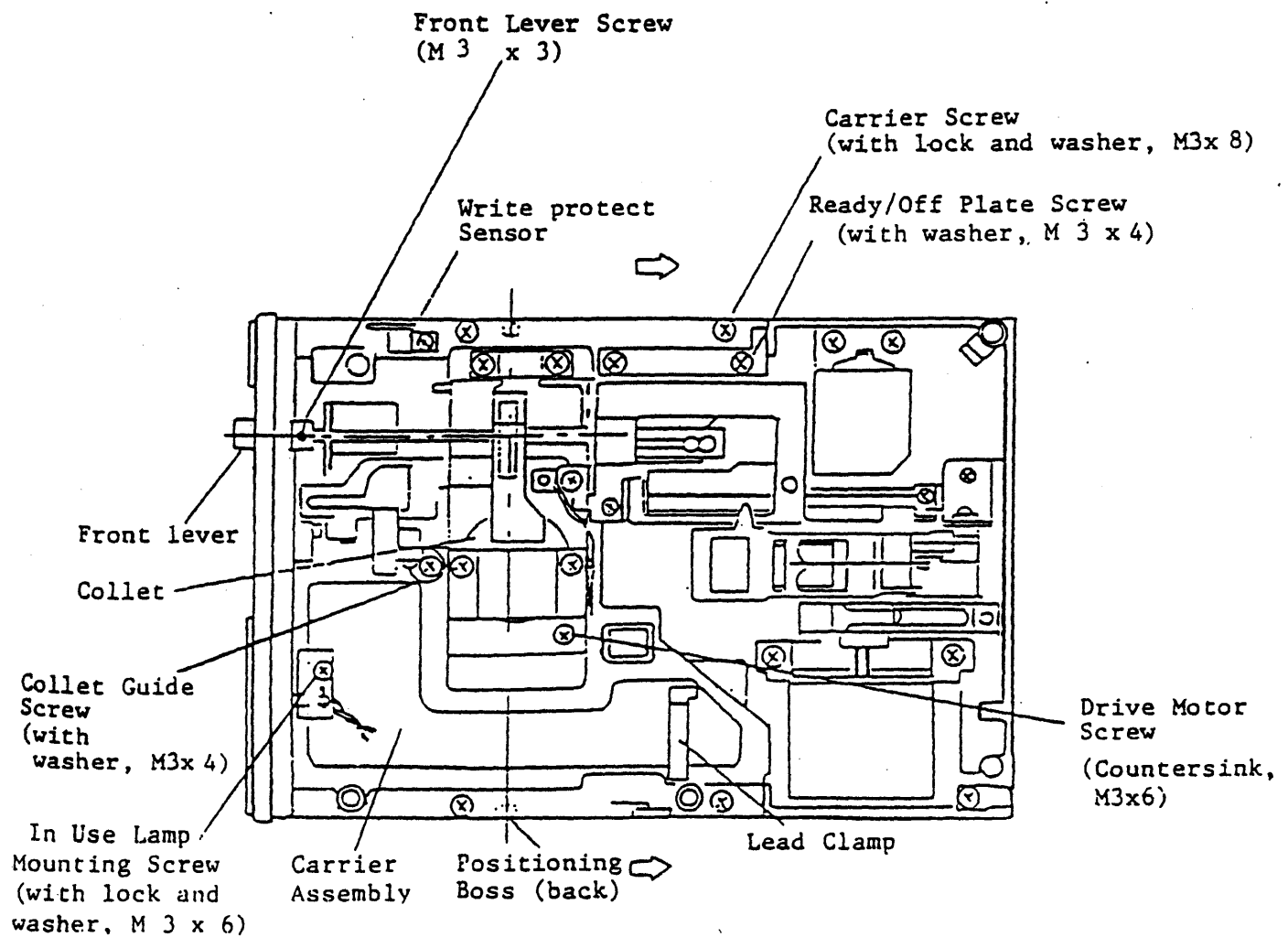

Figure 4.7.1

4.9 Drive Motor Assembly (Refer to Chapter 5, figure 2)

4.9.1 Service Check

1. Power up the drive.
2. Insert a disk and move the front lever to lock position.
3. Set the MOTOR ON signal on the interface to Low Level in order to start the drive motor.
4. Load the read/write heads against the disk.
5. Connect a counter to TP3 and GND on the PWB.
6. Verify that the index pulse period (TP3) is within $166.7 \text{ ms} \pm 1.5\%$ (164.2 to 169.2 ms).

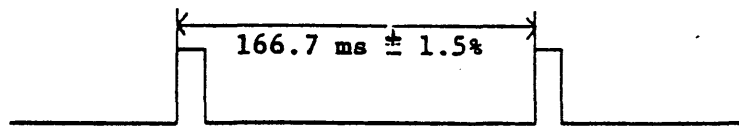

Figure 4.9.1

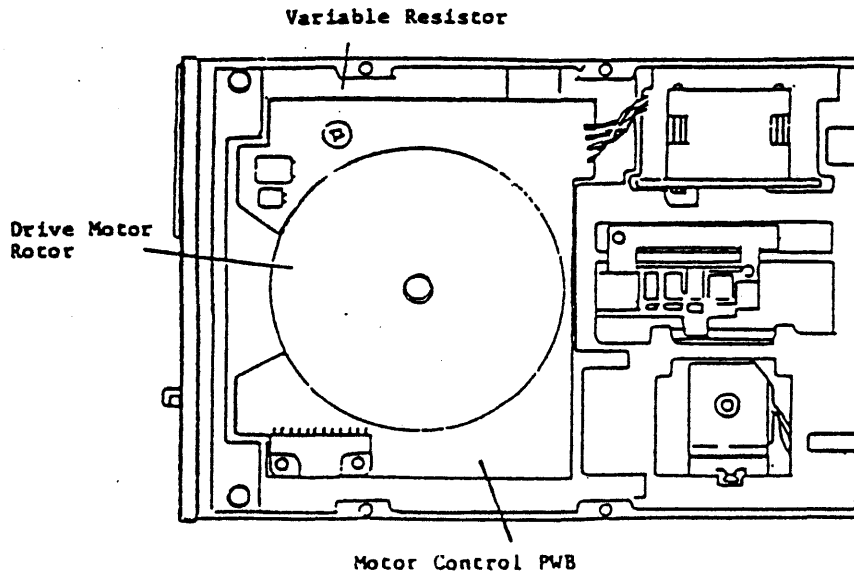

Figure 4.9.2

4.9.2 Removal and Replacement

1. Remove the PWB (See 4.1).
2. Remove J3 connector housing 3. (See page 9, figure 4.2.2)
3. Remove the carrier assembly. (See page 17, 4.7.1)
4. Remove the drive motor screws and remove the motor.
5. For reinstallation, reverse the above procedure.
6. Perform a service check (See page 20, 4.9.1).

4.9.3 Adjustment

1. Adjust the variable resistor on the motor control PWB with a Phillips head screwdriver until the index period is 166.7 ms $\pm 1.5\%$ (refer to figure 4.9.2)

4.10 Head Load Solenoid (Refer to Chapter 5, figure 3)

4.10.1 Service Check

1. Look through the disk inlet on the front bezel to make sure the pad on the bottom of the bail is normal.
2. Power up the drive.
3. Insert a disk and turn the front lever to lock position.
4. Load the read/write heads against the disk.
5. Make sure that there is a gap between the bail and the carriage arm throughout the carriage travel.
6. Power down the drive.
7. Remove the disk and turn the front lever to lock position.
8. Look through the disk inlet in the front bezel and verify that the gap between the unloaded read/write heads is within 0.3 to 0.7 mm. If the gap is larger, perform the adjustment described in 4.10.3.

4.10.2 Removal and Replacement

1. Remove the PWB (See 4.1).
2. Take out the screws attaching the Ready/Off plate to the carrier assembly and remove the Ready/Off plate.
3. Remove J3 connector housing 2. (See page 9, figure 4.2.2)
4. Cut the J3 cable tie wrap with cutters and remove the leads from the miniclamp.

CAUTION

Be careful not to damage the lead insulation when cutting the cable tie wraps.

5. Carefully insert a strip of clean paper into the disk slot of the head/carriage assembly from the front bezel.
6. Remove the head load solenoid screws. Lift up the carriage arm hanger slightly with your finger.
7. Slide out the solenoid by turning it clockwise.
8. For reinstallation, reverse the above procedure.

Note: When reinstalling the head load solenoid, make sure the bail rests under the carriage arm hanger.

9. Perform the adjustment on page 24, section 4.10.3.

4.10.3 Adjustment

1. Turn the adjusting screw on the Ready/Off plate until the gap between the read/write heads is within 0.3 to 0.7mm. Turning the screw clockwise increases the gap, counterclockwise decreases it.
2. Perform a service check (See 4.10.1)

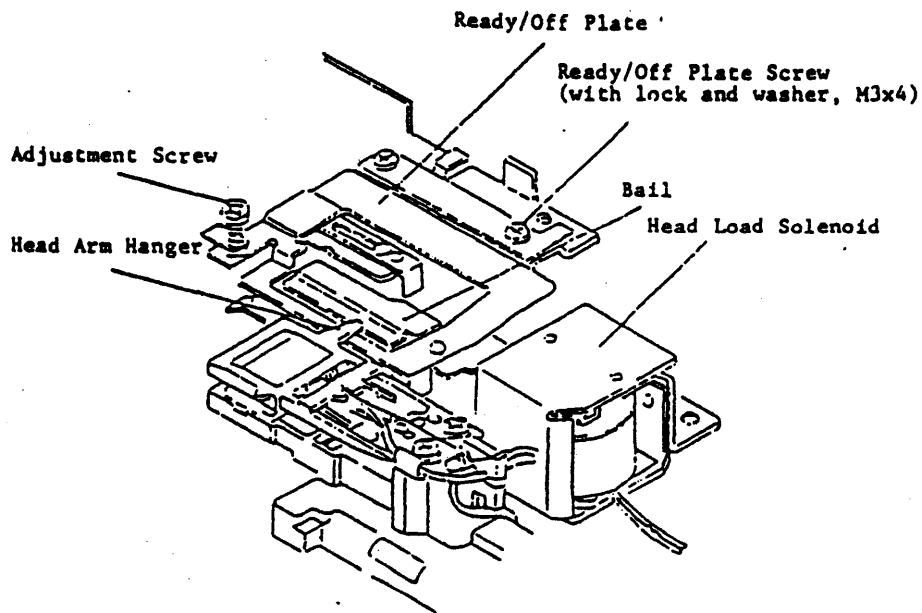

Figure 4.10.1

4.11 Front Lever (Refer to Chapter 5, Figure 5)

4.11.1 Removal and Replacement

1. Remove the carrier cover.
2. Turn the front lever to unlock position.
3. Remove the front lever screw with a hex wrench and take the crankshaft out via the front bezel.

CAUTION

Be careful not to lose the washer.

4. For reinstallation, reverse the above procedure.

Notes: 1) When attaching the front lever, push it against the washer before securing.

2) Attach the front lever so that the stop screw is even with the slot in the crank shaft.

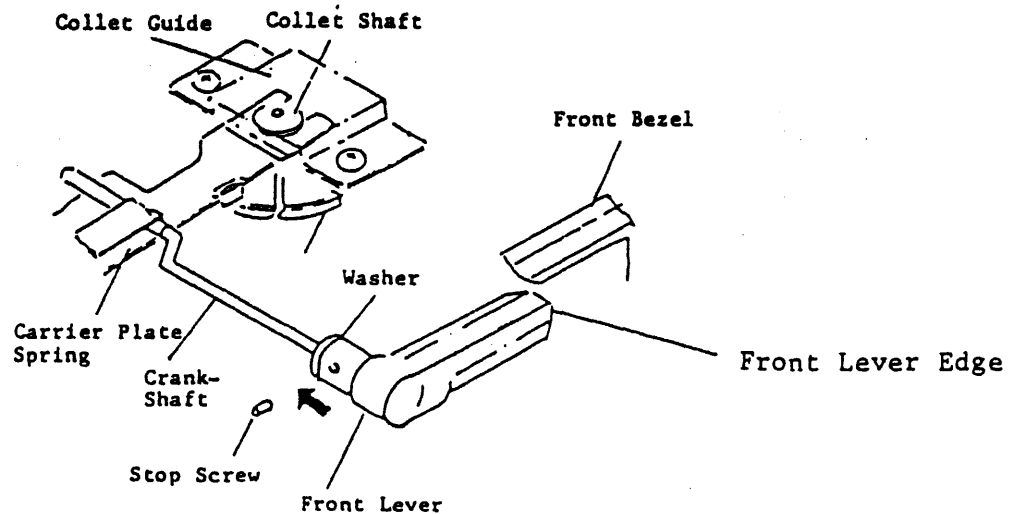

Figure 4.11.1

4.12 Front Bezel (Refer to Chapter 5, Figure 5)

4.12.1 Removal and Replacement

1. Remove the carrier cover.
2. Remove the front lever stop screw and the front lever.
3. Remove the front bezel screws and the front bezel.
4. For reinstallation, reverse the above procedure.

Notes: 1) When reinstalling the front bezel, make sure that that the bosses on the bezel fit correctly into the matching holes in the frame before securing.

2) Refer to section 4.11 for front lever attachment instructions.

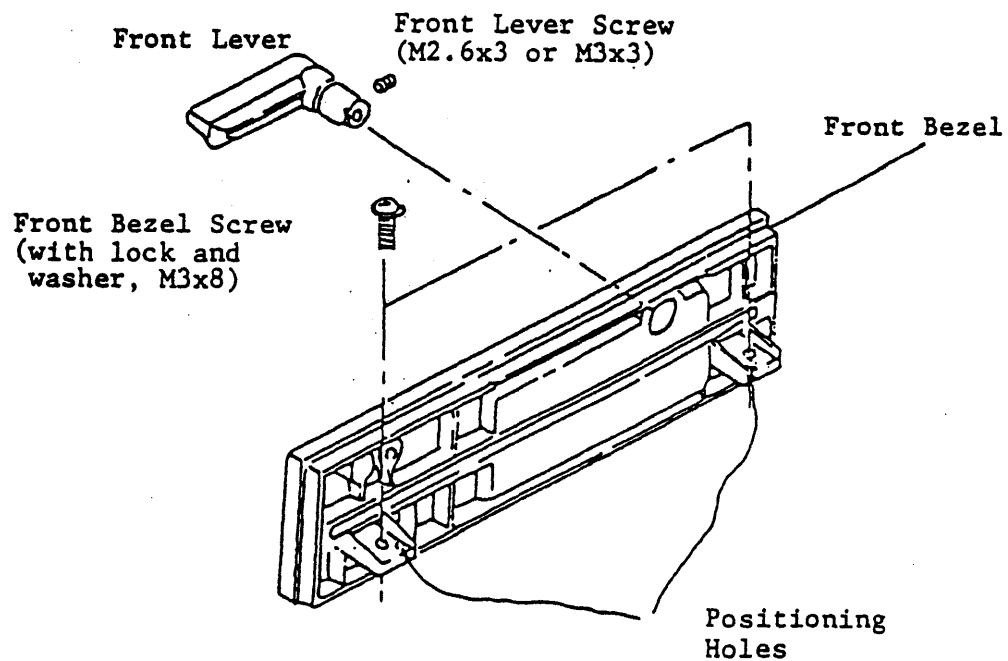

Figure 4.12.1

4.13 Stepper Assembly (Refer to Chapter 5, Figure 3)

4.13.1 Service Check

1. Power up the drive.
2. Check the head/carriage Seek operation by applying the Direction and Step signals to the interface.

4.13.2 Removal and Replacement

1. Remove the PWB. (See 4.1)
2. Remove J3 connector housing 1. (See page 9, figure 4.2.2)
3. Remove the belt clamp C securing screw (M2.6) from top of the frame.
4. Remove the steel belt assembly screw (M2.6) the top of the frame.
5. Remove the stepper screw from the frame.
6. Gently unloop the steel belt from the stepper.
7. For reinstallation, reverse the above procedure.

Note: When reinstalling, do not tighten the belt clamp and the steel belt assembly screws completely. Move the carriage forward and backward with your hand, making sure that it moves smoothly in both directions. If carriage movement is normal, secure the screws.

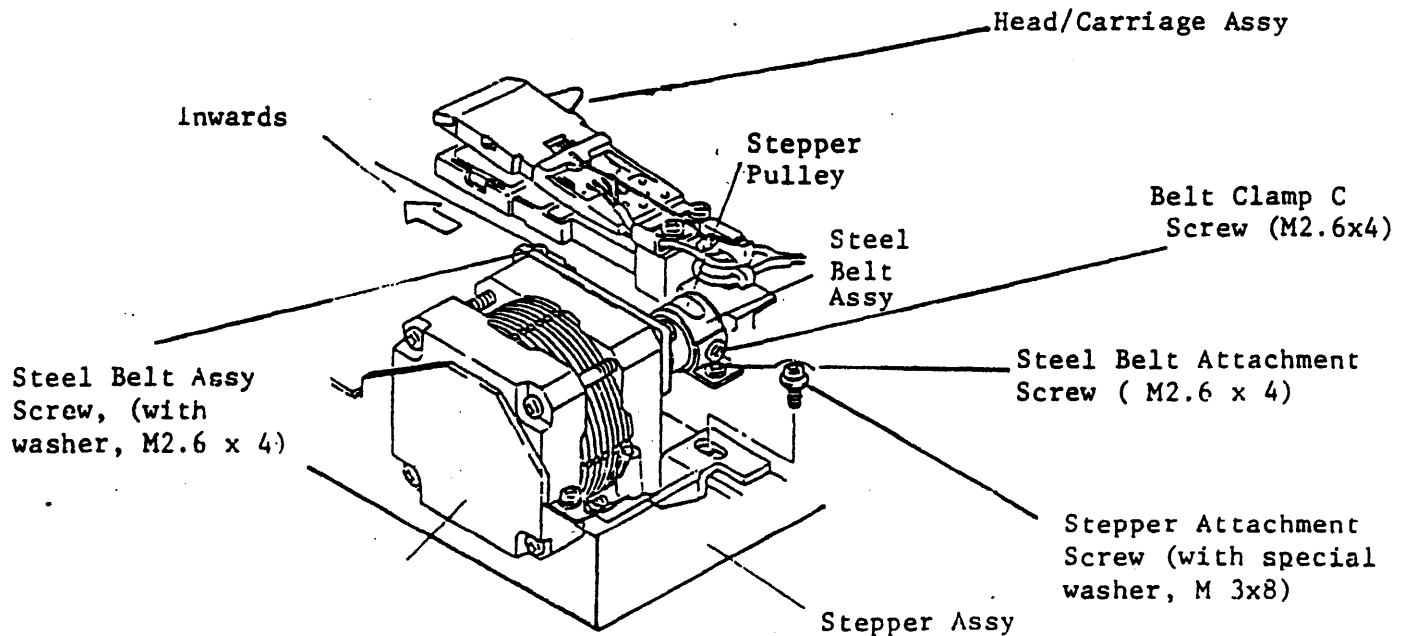

Figure 4.13.1

4.13.3 Adjustment

1. Perform the position adjustment for the carriage assembly (see 4.14.3).

4.14 Head/Carriage Assembly (Refer to Chapter 5, Figure 3)

CAUTION

The head/carriage assembly is factory adjusted and tested. Never attempt to adjust or repair this internal component.

4.14.1 Radial Alignment Check

1. Power up the drive. (Resets the PWB memories)
2. Set up a dual trace oscilloscope.
 - Connect channel 1 to PWB test point 1A.

- Connect channel 2 to PWB test point 1B.
- Connect scope ground to PWB test point G (GND).
- Connect the external scope trigger probe to PWB test point 3.

Set the oscilloscope controls as follows:

INPUT COUPLING MODE	AC
VERT MODE	ADD
INVERT (CH 2)	ON
TIME/DIV	20 ms
VOLTS/DIV (CH 2)	20 mv

3. Insert a CE disk and turn the front lever to lock position.
4. Load the read/write heads against the disk and make sure the Track 00 signal (J1-26) is at Low level (0 to 0.4 V).
5. Step the head/carriage from Track 00 to 32. Obtain A/B or B/A, the ratio between the two amplitude lobes on the scope. Convert the ratio to a position on the CE disk conversion chart. The positioning error should be within $\pm 25 \mu\text{m}$ (See figure 4.14.1, figure 4.14.2).
6. Step the head/carriage from track 33 to track 32 and check the positioning as in step 5 above.

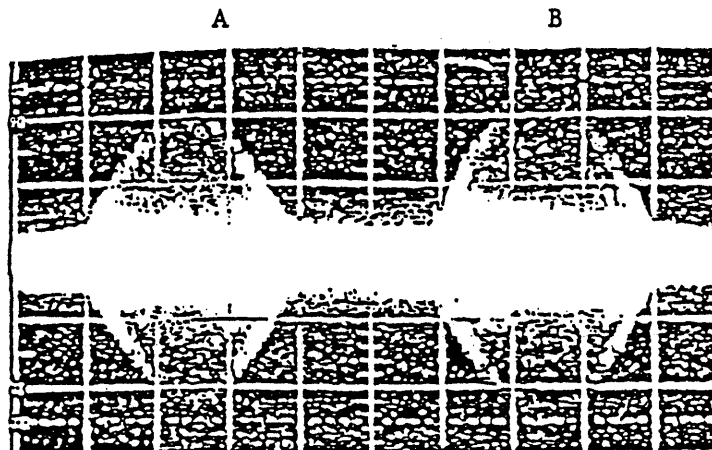

Figure 4.14.1

HOW TO USE THE CE DISK AND CONVERSION CHART

1. Preparation

- a) The test should be performed at a temperature of 13°C to 33°C, and a relative humidity of 20% to 80%. Humidity compensation is required if the humidity is not 50%.
- b) Before using the CE disk, allow a minimum of two hours for the drive (with DC power on) and the disk to adapt to the ambient temperature and humidity of the test area.

2. Measurement

- a) Refer to 4.14.1 for test equipment and set-up procedure.
- b) Find the positioning error corresponding to A/B or B/A on the conversion chart printed on the CE disk envelope.

Example: When $B/A = 0.9$, the conversion chart shows the positioning error to be $+P \mu\text{m}$.

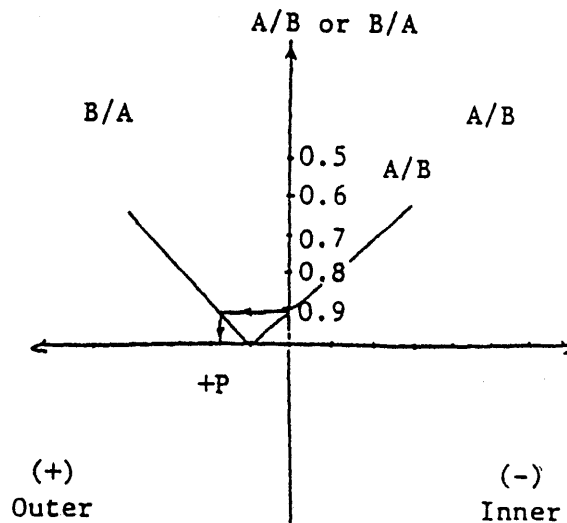

Figure 4.14.2

c) Compensation (for humidity only)

$$\text{Humidity Compensation } Ph = B \times (h - 50)$$

Where h is ambient humidity (%RH)

$$B = +0.25 \mu\text{m} / \%RH = \text{Compensation Coefficient}$$

Compensated Positioning Error

$$PO = P + Ph = P + 0.25 (h - 50)$$

$$\begin{aligned} \text{Example: If } h = 70\% \text{ RH, } PO &= P + 0.25 (70 - 50) \\ &= P + 5 \mu\text{m}. \end{aligned}$$

4.14.2 Removal and Replacement

1. Remove the PWB. (See 4.1)
2. Disconnect the J4 connector from the PWB. Remove the head cable from the groove in the carrier base.
3. Take out the Ready/Off plate screws and remove the Ready/Off plate. (See figure 4.10.1)
4. Remove the stepper. (See 4.13.2)
5. Remove the long guide bar clamps (two locations) and lift out the head/carriage assembly and guide bar together.
6. When reassembling, reverse the above procedure.

CAUTION

When reinstalling, be careful not to push on the head arm hanger of the head/carriage assembly.

4.14.3 Position Check

1. Make sure the gap between the unloaded read/write heads is within 0.3 to 0.7 mm. (See 4.10.3)

2. Set up a dual trace oscilloscope.
 - Connect channel 1 to PWB test point 1A.
 - Connect channel 2 to PWB test point 1B.
 - Connect scope ground to PWB test point G (GND).
 - Connect the external scope trigger probe to PWB test point 3.

Set the oscilloscope controls as follows:

COUPLING MODE	AC
VERT MODE	ADD
INVERT (CH 2)	ON
TIME/DIV	20 ms
VOLTS/DIV (CH 1, CH 2)	20 mV

3. Insert a CE disk and power up the drive.
4. Seek the carriage 32 steps inwards.
5. Load the read/write heads against the disk. Insert a screwdriver through the notch in the PWB (figure 4.14.3) and move the stepper in or out to obtain the position signal shown in figure 4.14.1.

Note: For this adjustment, tighten the stepper attachment screws and then loosen 1/4 turn.

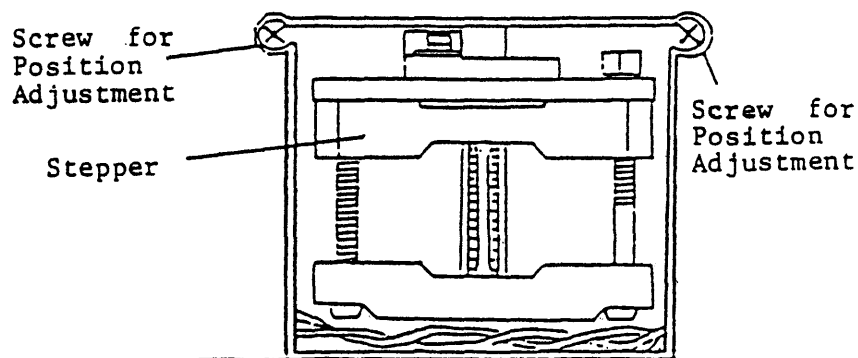
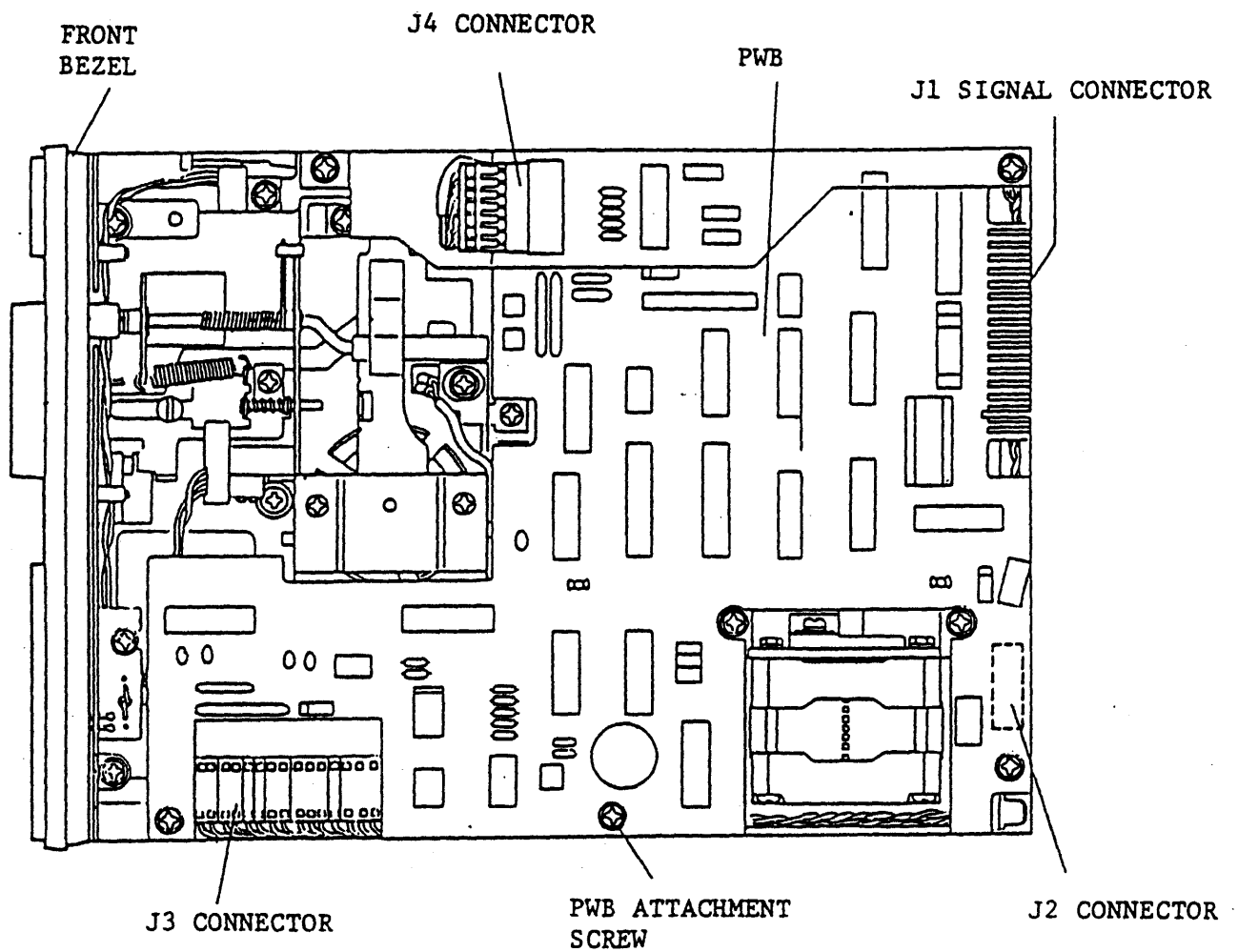

Figure 4.14.3

6. In step 5 above, move the stepper according to the following:
 - If $A > B$ move inwards
 - If $A < B$ move outwards.
7. Obtain A/B or B/A from the side 0 read output and verify that the position error is within $\pm 25 \mu\text{m}$ with the CE disk conversion chart.
8. Step the carriage from track 33 to track 32 and make sure the read output, A/B or B/A, is the same as in step 7. If not, repeat step 6.
9. Check that the read output from side one is within the limits given in steps 7 and 8.
10. Perform steps 3 and 4 above to check for the cat's eyes display.
11. Move the carriage out 32 steps after performing step 10, and verify that the Track 00 signal (J1 - 26) is at Low level.

5.0 PARTS/ASSEMBLES LOCATIONS



YD-380 Top View

Figure 1

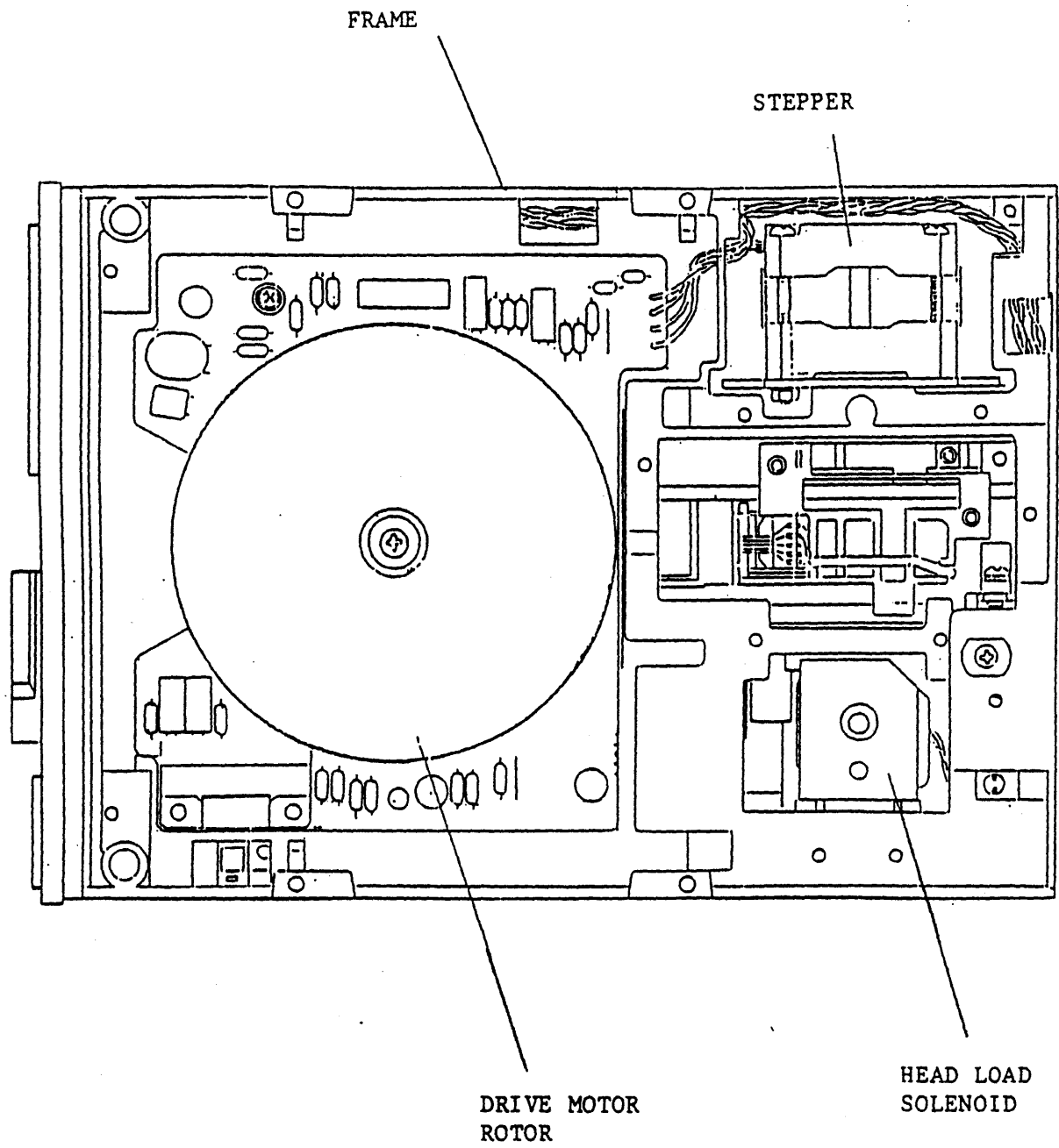

YD-380 Bottom View

Figure 2

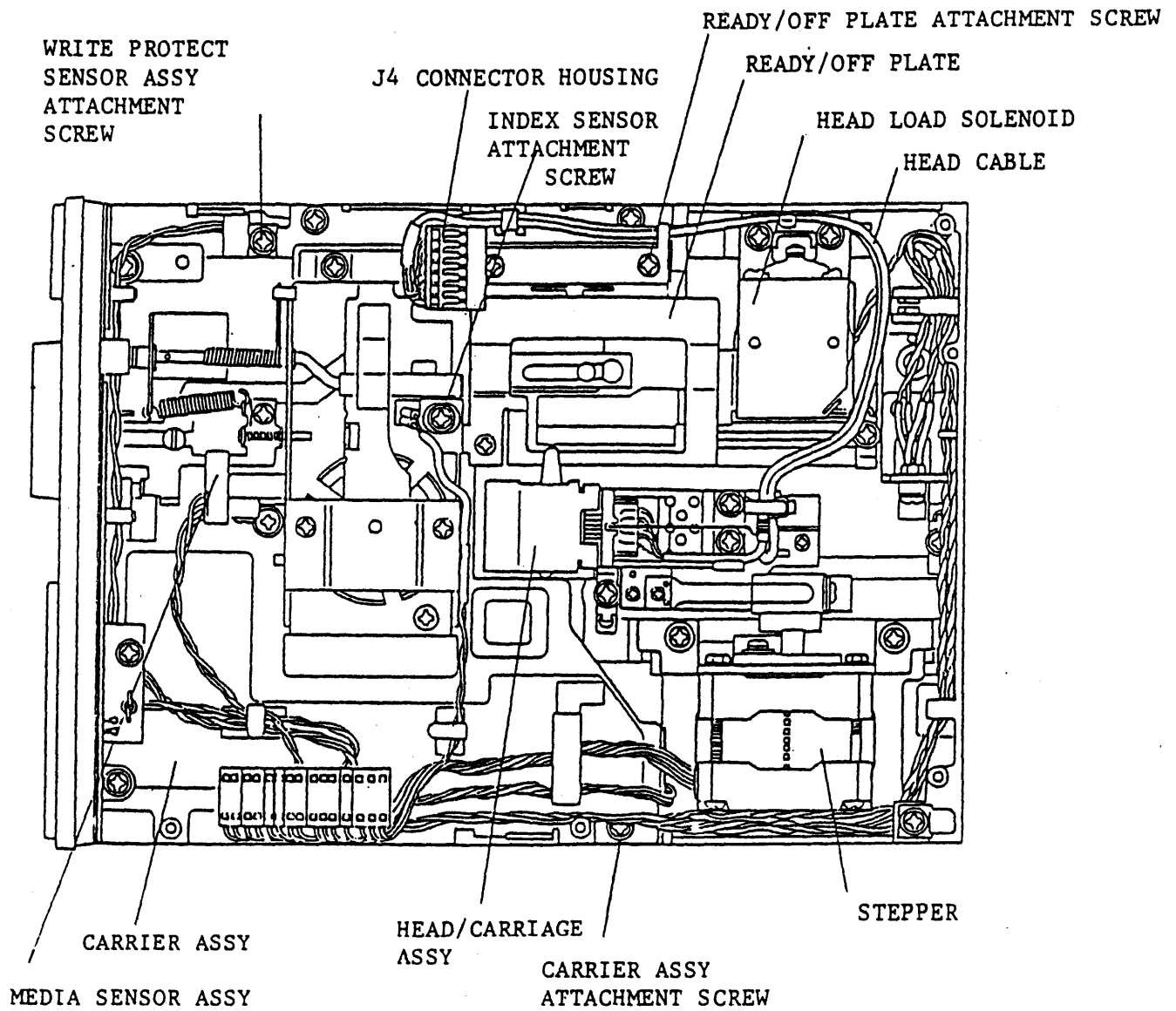

YD-380 Top View (with PWB removed)

Figure 3

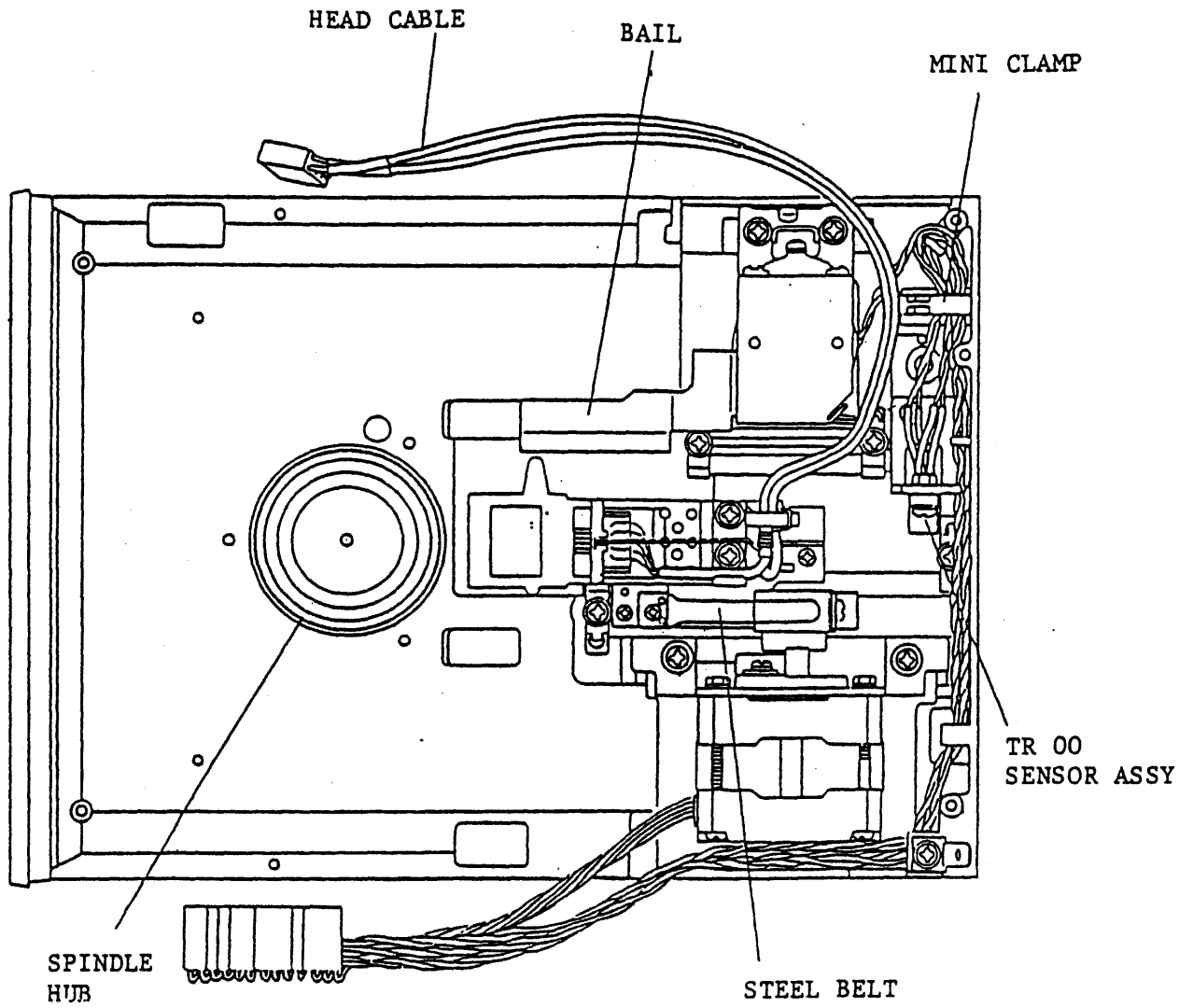

YD-380 Top View
 (with PWB and carrier assembly removed)

Figure 4

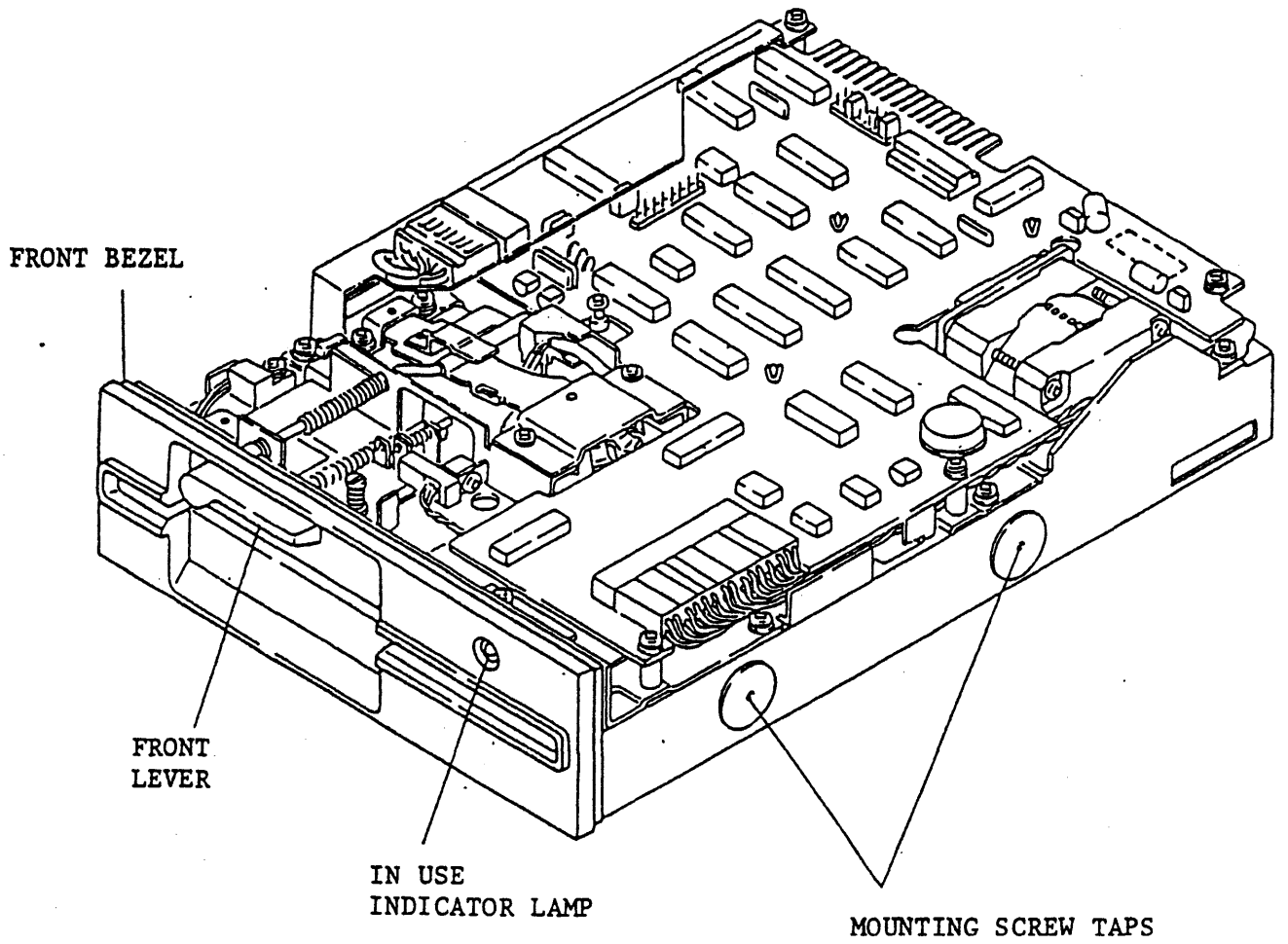

YD-380 Front View
Figure 5

6.0 TEST POINT/CONNECTOR PIN ASSIGNMENTS (-1710)

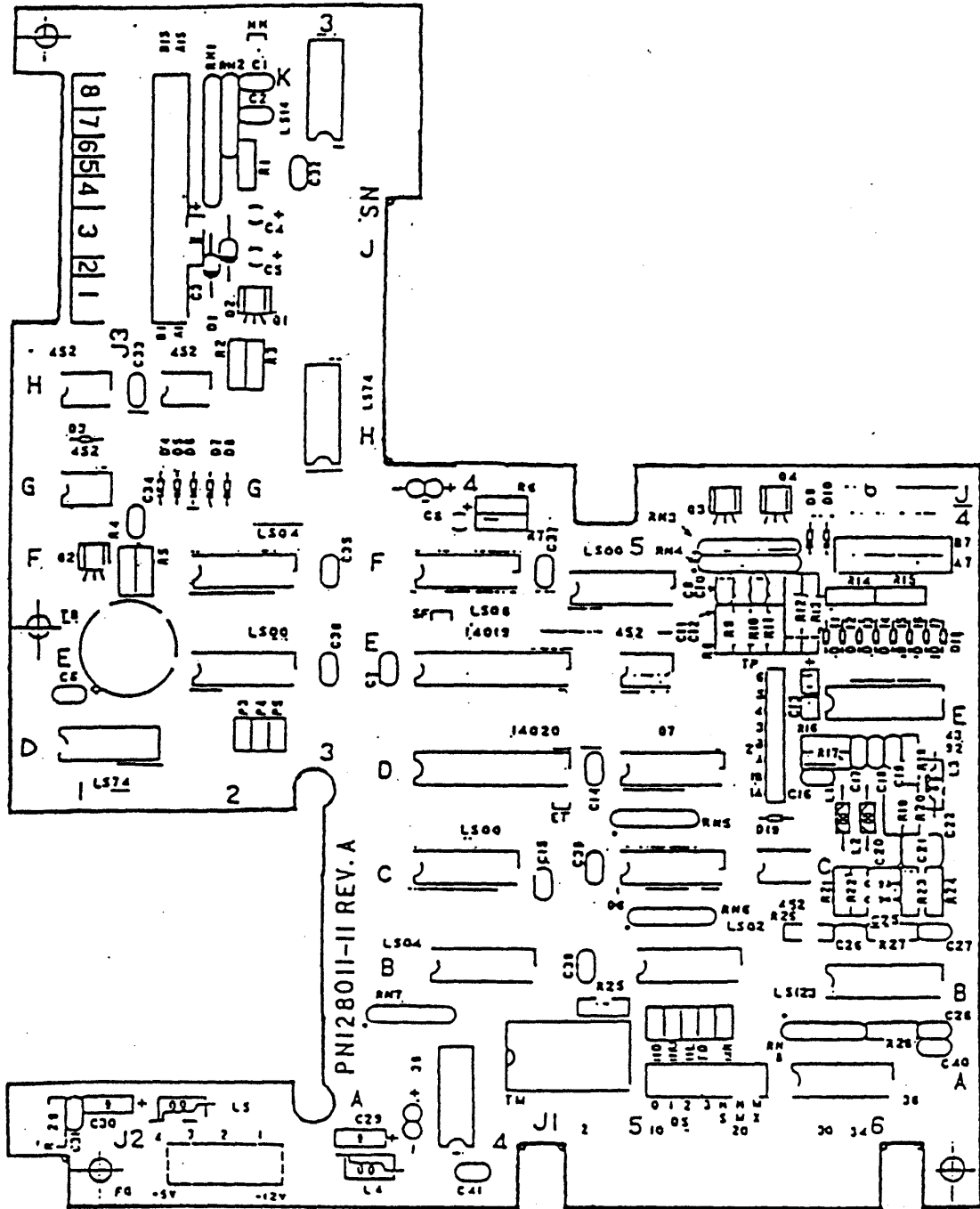

INTERFACE - J1

Pin No.	Signal Name
1	RETURN
2	
3	RETURN
4	HEAD LOAD (IN USE) ,
5	RETURN
6	DRIVE SELECT 3
7	RETURN
8	INDEX
9	RETURN
10	DRIVE SELECT 0
11	RETURN
12	DRIVE SELECT 1
13	RETURN
14	DRIVE SELECT 2
15	RETURN
16	MOTOR ON
17	RETURN
18	DIRECTION SELECT
19	RETURN
20	STEP
21	RETURN
22	WRITE DATA
23	RETURN
24	WRITE GATE
25	RETURN
26	TRACK 00
27	RETURN
28	WRITE PROTECT
29	RETURN
30	READ DATA
31	RETURN
32	SIDE ONE SELECT
33	RETURN
34	READY

TRANSDUCER - J3

Pin No.	Signal Name	Color
A 1	STEPPER D	ORANGE
B 1	STEPPER A	BLACK
A 2	STEPPER (+12V)	RED
B 2	STEPPER B	YELLOW
A 3	STEPPER (+12V)	RED
B 3	STEPPER C	BROWN
A 4	HEAD LOAD SOLENOID (+12V)	WHITE
B 4	HEAD LOAD SOLENOID	GREEN
A 5	DRIVE MOTOR (+12V)	RED
B 5	DRIVE MOTOR (GND)	BLACK
A 6	MOTOR ON	BLUE
B 6	KEY	—
A 7	INDEX SENSOR LED	ORANGE
B 7	—	—
A 8	W/P SENSOR LED	YELLOW
B 8	KEY	—
A 9	W/P SENSOR PTK	ORANGE
B 9	W/P SENSOR RET.	BLACK
A 10	IN USE LED (ANODE)	RED
B 10	IN USE LED (CATHODE)	BLACK
A 11	INDEX SENSOR PTK	BLUE
B 11	INDEX SENSOR PTK RET.	BLACK
A 12	TRACK 00 SENSOR	GREEN
B 12	TRACK 00 SENSOR LED RET.	BLACK
A 13	TRACK 00 SENSOR PTK	BROWN
B 13	TRACK 00 SENSOR PTK RET.	BLACK
A 14	MEDIA SENSOR LED	YELLOW
B 14	MEDIA SENSOR RET.	BLACK
A 15	MEDIA SENSOR PTK	BLUE
B 15	—	—

HEADS - J4

Pin No.	Signal Name	Color
A 1	SHIELD (HEAD 0)	—
B 1	SHIELD (HEAD 1)	—
A 2	—	—
B 2	KEY	—
A 3	ERASE (HEAD 0)	RED
B 3	ERASE (HEAD 1)	RED
A 4	W/R ERASE COMMON(HEAD 0)	GREEN
B 4	W/R ERASE COMMON(HEAD 1)	GREEN
A 5	W/R (HEAD 0)	BLACK
B 5	W/R (HEAD 1)	BLACK
A 6	—	—
B 6	—	—
A 7	W/R (HEAD 0)	WHITE
B 7	W/R (HEAD 1)	WHITE

TEST POINTS

Pin No.	Signal Name
1A	PRE AMP. OUTPUT 1A
1B	PRE AMP. OUTPUT 1B
2A	DIFFERENTIATOR OUTPUT 2A
2B	DIFFERENTIATOR OUTPUT 2B
3	INDEX
4	ERASE
5	TRACK 00
G	GROUND

DC - J2

Pin No.	Signal Name
1	+12V DC
2	+12V RETURN
3	+ 5V RETURN
4	+ 5V DC

7.0 SPARE PARTS LIST

Maintenance Level 1

P/N	Part
128012-11	PWB
145004-01	Index Sensor Assembly
148026-02	Track 00 Sensor Assembly
145050-01	Write Protect Sensor Assembly
145050-03	Media Sensor Assembly
148013-02	In Use Lamp Assembly

Maintenance Level 2

P/N	Part
128007-04	Carrier Assembly
148085-01	Drive Motor Assembly (on Motor Control PWB)
138001-11	Head Load Solenoid
135030-01	Front Lever
128004-01	Front Bezel
138023-01	Stepper Assembly
128026-01	Carriage Assembly

8.0 SCHEMATIC DIAGRAMS

1. Revision of schematics is controlled under a revision code, which is printed on both the PWB and the schematics.
2. The revision code of the attached schematics is as follows:

Part	P/N	Drawing	Rev.
PWB	128012-11	138012-11	B
Drive Motor Control PWB	148085-01	138061-01	A

3. For actual maintenance, use the schematics with the same revision number as the drive to be serviced.

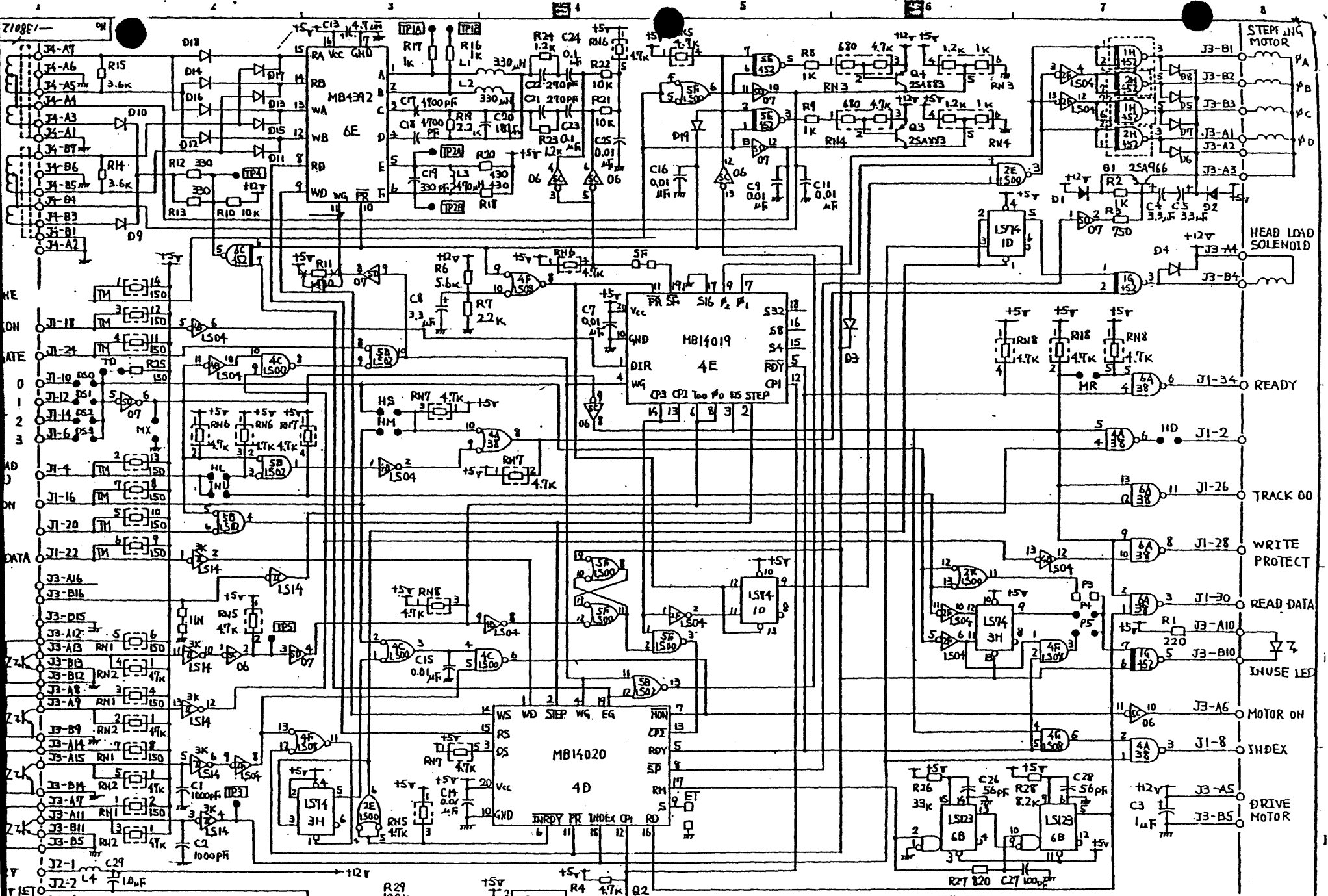

APPROVED BY				CHECKED BY				TRACED BY				DESIGNED BY				NAME			
* * *				* * *				* * *				* * *				* * *			
FLOPPY DISK DRIVE												128012-11							
INTERNAL CIRCUIT												REV. B		SHEET 1/1					
MODEL YD-380-1710												DWG. NO. □ □							
SYSTEM												-138012-11							

REV	DATE	REVISION DESCRIPTION	SIGN	ECO NO.
B	'83-6-16	Relation of the C10-C12		

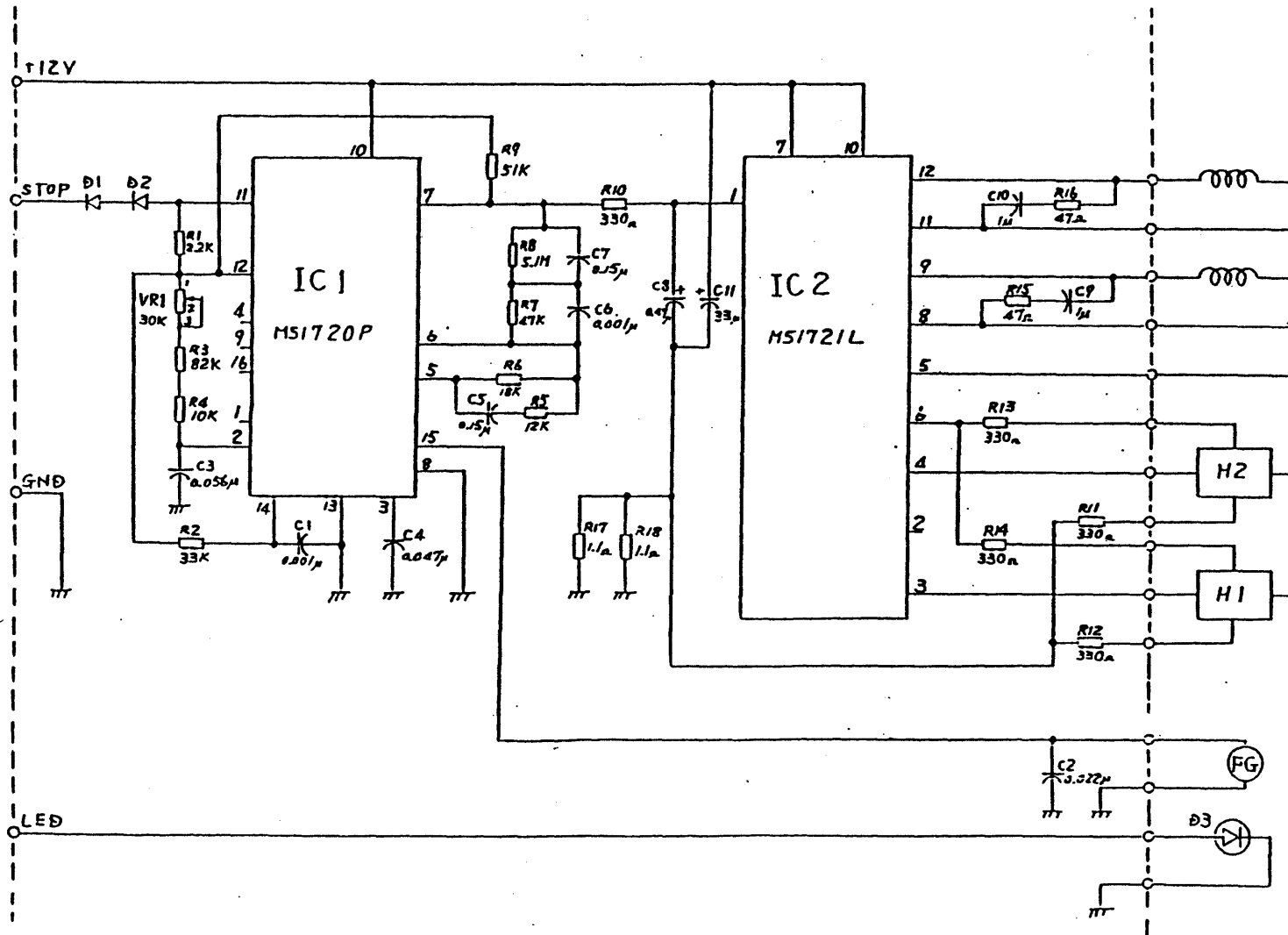

D1, D2 --- 1SS53

APPROVED BY * * *	CHECKED BY * * *	TRACED BY * * *	DESIGNED BY * * *	NAME DRIVE MOTOR S * CONTROL PWB	NEXT ASSY. * * *
K. Hashimoto May 14 - 83				S. OSADA K. Tanaka 83-5-14 83-5-14	REV. A SHEET 1/1
MODEL YD-380 SYSTEM R &				DWG. NO. 138061-01	

REV.	改訂	DATE	日	REVISION DESCRIPTION	理由	SIGN	印	ECO NO.	印



9.0 EXPLODED VIEW

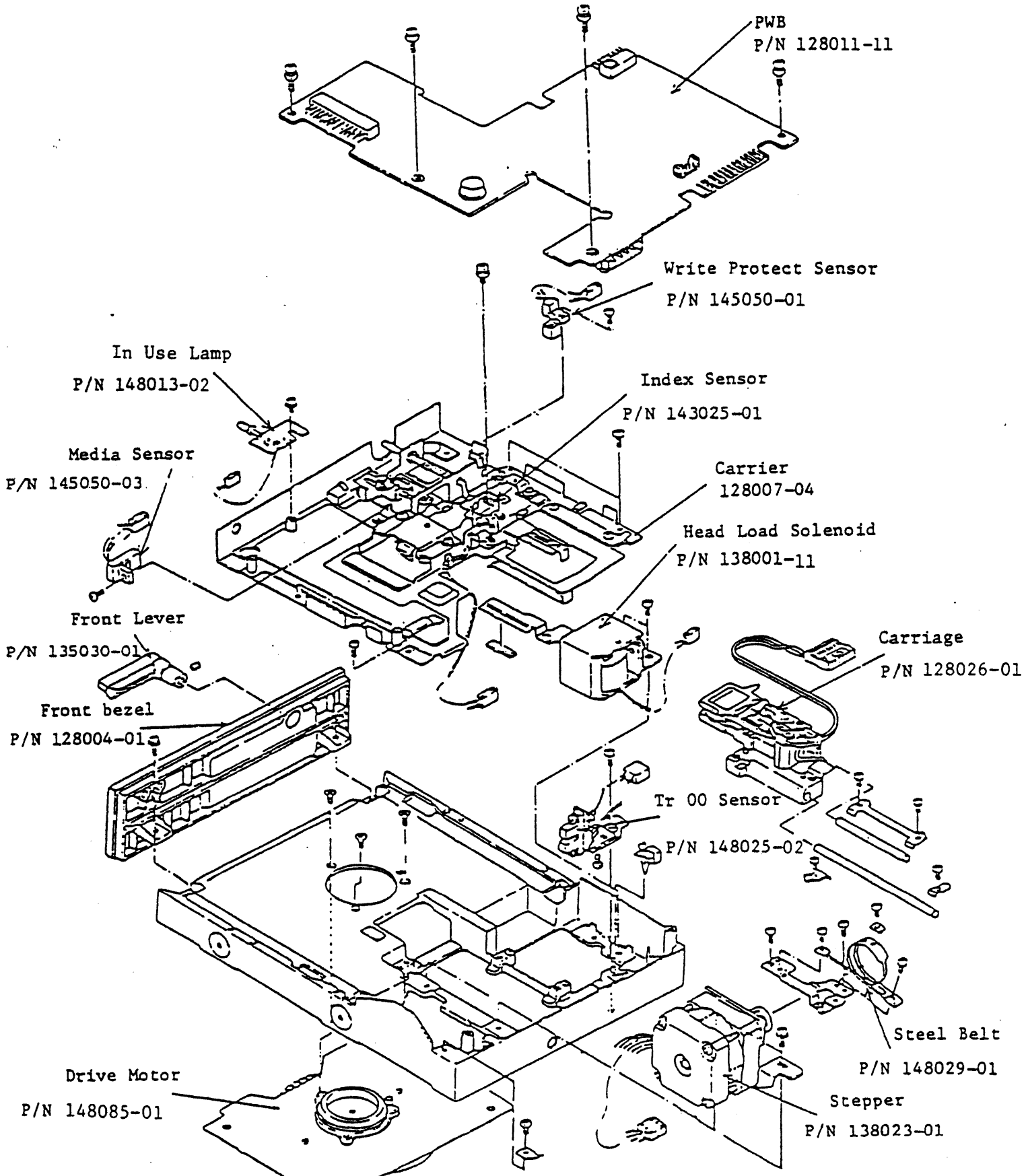

10.0 USING A CLEANING DISK

10.1 One of the problems with using different kinds of floppy disks in the field is the build up of magnetic particles on the head surfaces, which can reduce read/write capability. Two ways to effectively eliminate this problem are direct cleaning of the heads and proper disk management. Because the structure of the heads makes direct cleaning difficult, we recommend using a cleaning disk.

10.2 Recommended Cleaning Disk:

Maker: Nagase Sangyo

Model: CFD 5W

10.3 Head Cleaning Procedure

10.3.1 Dirty head surfaces can cause read errors and damage the magnetic surface of a disk. If these problems begin to occur, use the cleaning disk to clean the heads.

10.3.2 Procedure

1. Power up the disk drive and insert the cleaning disk in the same way as a normal disk.
2. Load the read/write heads against the disk.
3. In order to increase the effectiveness of the cleaning disk, the heads should come in contact with as much of the disk as possible. Step the carriage in and out during cleaning.
4. One cleaning should take no more than 5 minutes.
5. To determine if cleaning is completed, check with a regular disk (new if possible) to see if the read/write functions are error free and operating normally.

6. If it appears that cleaning is not complete, repeat steps 4 and 5 up to 5 times. When repeating, try to use a new cleaning disk.
7. The recommended cleaning disk should have no effect on the YD-380 even after 10 hours of cleaning.
8. The life span of the cleaning disk is about one hour of usage, after which the effect is lost due to silting of the disk surface.

10.3.3 Head Cleaning as a Part of Preventive Maintenance

1. In order to maintain read/write capability, we recommend that head cleaning be performed as a part of preventive maintenance.
2. Cleaning procedure is the same as 10.3.2 above.